

# Spider Web Net

General Information - Page 1 of 2

Revision - 0  
Saved Date 24 September 2015 14:37:04

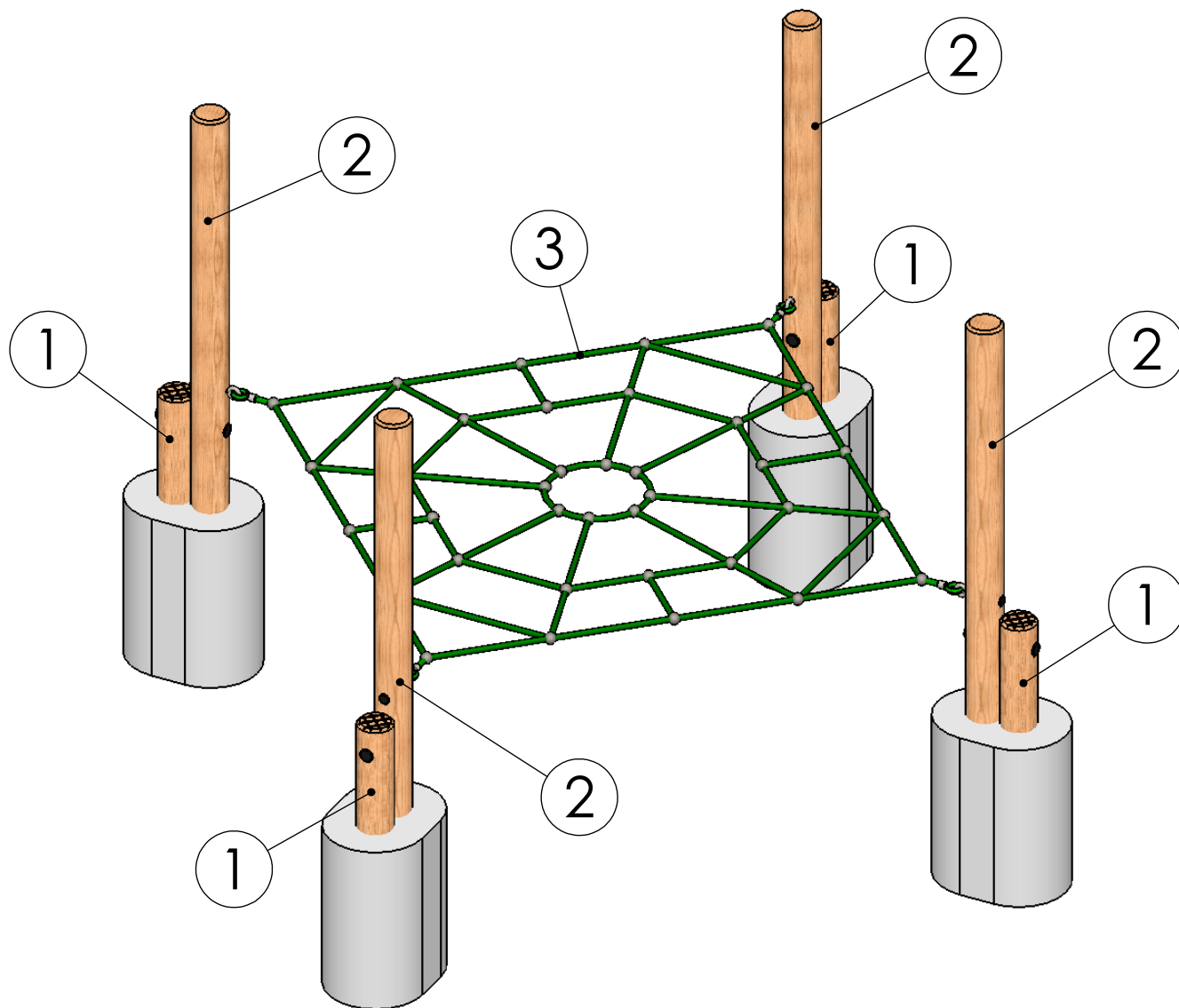

ITEM NO.	PART NUMBER	DESCRIPTION	QTY.
1	T2096	Timber 125mm dia cut at 1000mm SC	4
2	T2100	Timber 125mm dia. cut at 2100mm SC	4
3	B0370	Spider Web Net	1



Statement of Compliance: AE Evans Ltd. manufacturers of children's playground equipment follow the codes and practices outlined in the British and European Standards. By doing this, all equipment for play areas manufactured by AE Evans meets the requirements of BSEN 1176 (general safety and test methods). Spares can be supplied via equipment distributor.

# Spider Web Net

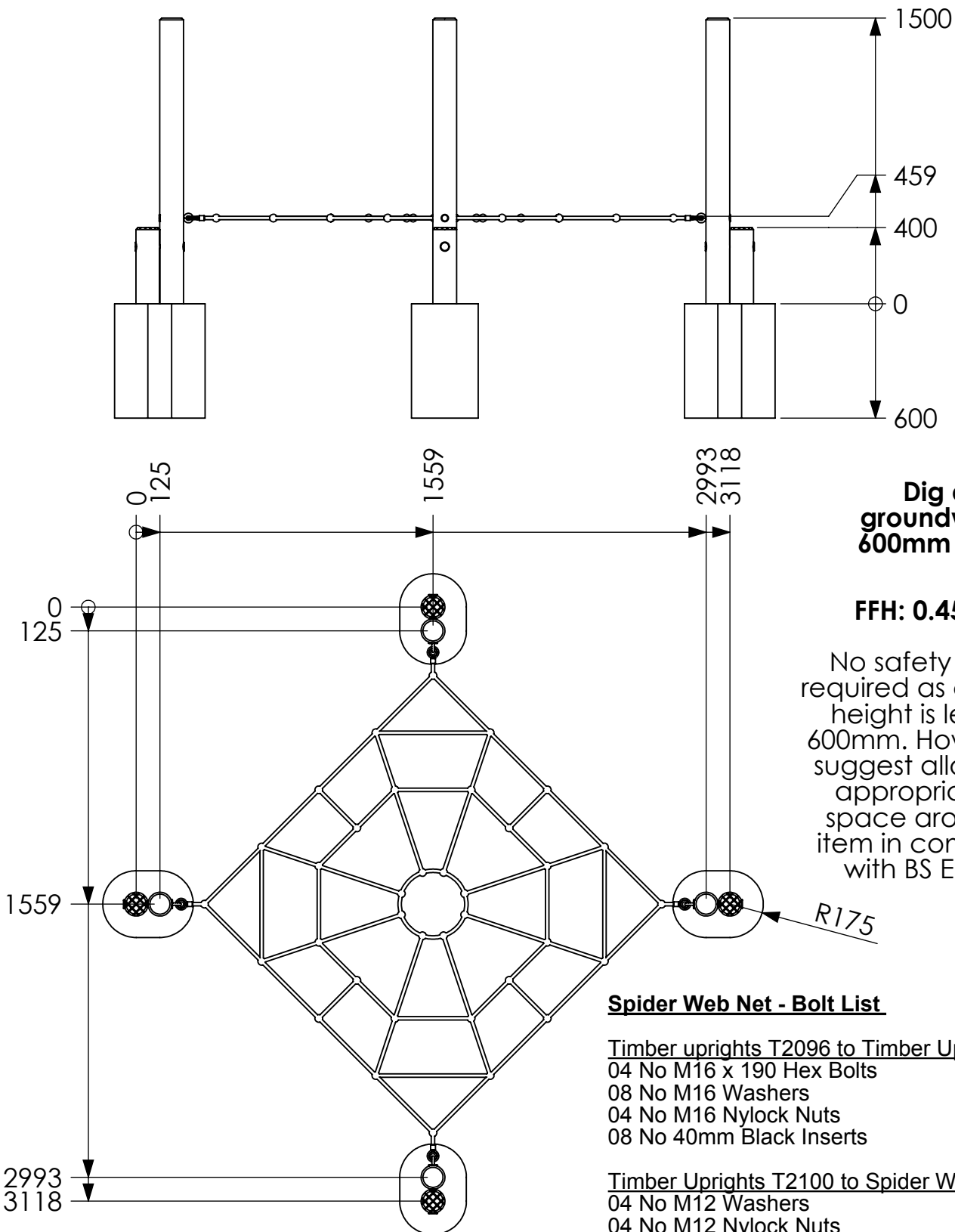

**Dig all groundworks 600mm deep**

**FFH: 0.459mm**

No safety surface required as critical fall height is less than 600mm. However we suggest allowing an appropriate free space around the item in compliance with BS EN1176.

**Spider Web Net - Bolt List**

Timber uprights T2096 to Timber Uprights T2100

- 04 No M16 x 190 Hex Bolts
- 08 No M16 Washers
- 04 No M16 Nylock Nuts
- 08 No 40mm Black Inserts

Timber Uprights T2100 to Spider Web Net B0370

- 04 No M12 Washers
- 04 No M12 Nylock Nuts
- 04 No 33mm Black Inserts

01 No "B0370" Spider Web Net

**Please note additional fixings have been included therefore you may have left overs**

