

Rope Weave

General Information - Page 1 of 2

Revision - 0
Saved Date 05 February 2016 09:36:36

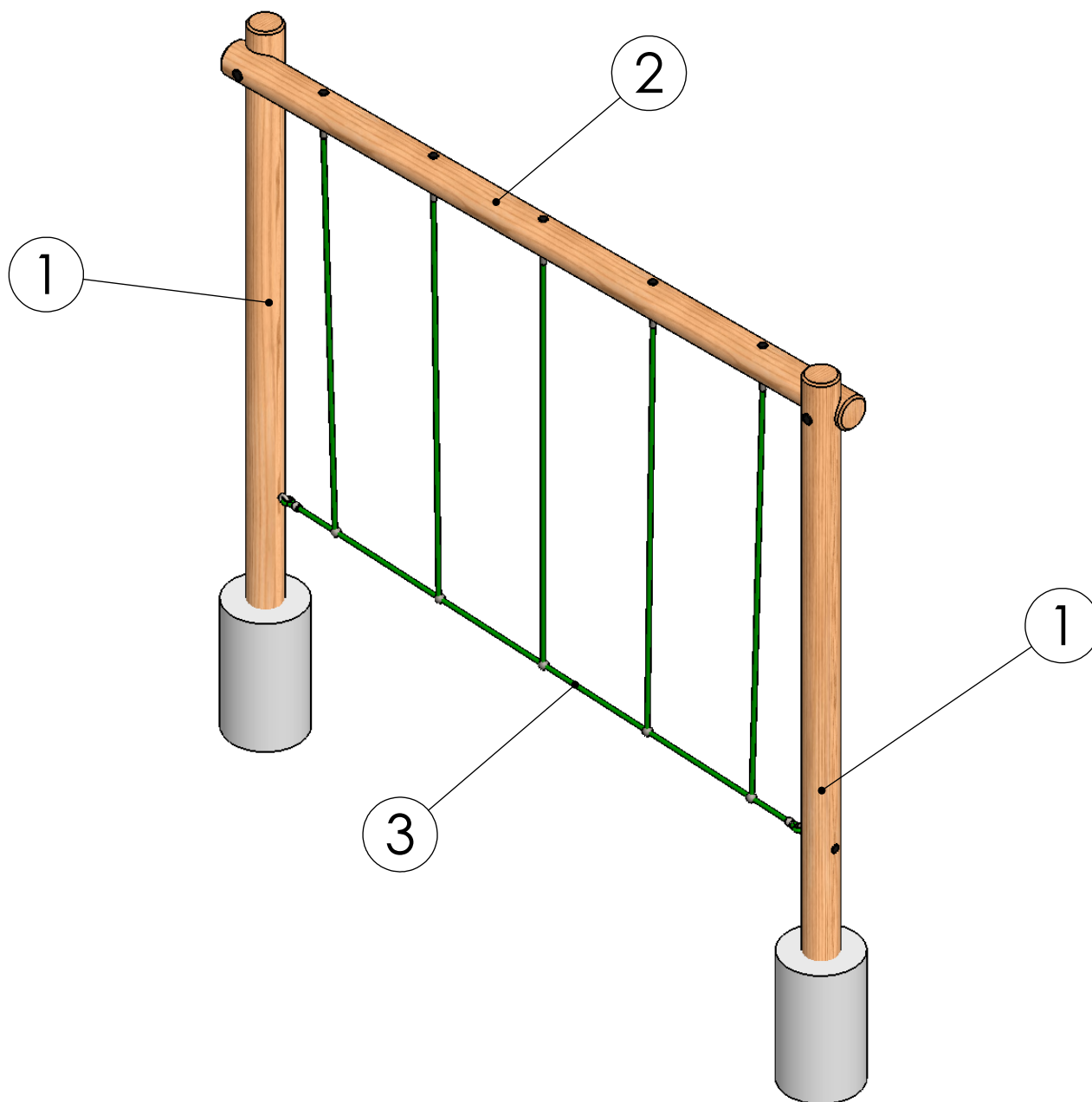

ITEM NO.	PART NUMBER	DESCRIPTION	QTY.
1	T1545	Timber 150mm dia. cut at 3300 SC	2
2	T1365	Timber 150mm dia. cut at 3350mm DC	1
3	B0372.	Rope Weaver Net	1



Statement of Compliance: AE Evans Ltd. manufacturers of children's playground equipment follow the codes and practices outlined in the British and European Standards. By doing this, all equipment for play areas manufactured by AE Evans meets the requirements of BSEN 1176 (general safety and test methods). Spares can be supplied via equipment distributor.

