

## FZ33 - Zone Leg Workout Combo



Steel sections are all mild steel to the relevant BS EN steel standards.

Plastic panels are made from long lasting HDPE

Fixings are mostly BZP, high tensile steel, hex head bolts with washers and Nyloc nuts.

### Coatings

All steel equipment made by Play & Leisure is shotblasted to SA 2.5 before a 60-micron thick epoxy based zinc phosphate primer is applied and finally a 70 micron thick coating of polyester powder.

All Play & Leisure Ltd's equipment & surfacing complies to BS EN 1176 parts 1-10, BS EN 1177 and BS EN 15312. Equipment is guaranteed for 25 years against structural failure.

### INSTALLATION INSTRUCTION

1. There is no requirement for safety surfacing beneath outdoor fitness equipment, but please observe the 1.5m minimum space requirement for each item of equipment (drawings available)
2. Excavate holes and lower ground anchor/base into position and level in all directions. See Fig 1
3. Attach the leg push to the main post using M12 x 135 bolt, 2 x steel washers & 2 cap sets.
4. Attach the slalom to the main post using M10 x 35 bolt & washer, followed by fitting the plastic cap
5. Loosely bolt the assembled kit to the bases using M12 x 45 bolts (See Fig. 2) to correctly align the bases
6. Pour in 0.4m<sup>3</sup> of low slump concrete and vibrate down with vibrating poker.
7. Re-check levels in all directions

Do not leave unattended until satisfied the concrete has cured or the site is secure.

8. Re-instate the ground around the base plate, as desired, to the level shown in Fig. 1
9. Ensure fastenings are tight and cover with black plastic caps

# FZ33 - Zone Leg Workout Combo

Foundation Detail(fig 1)

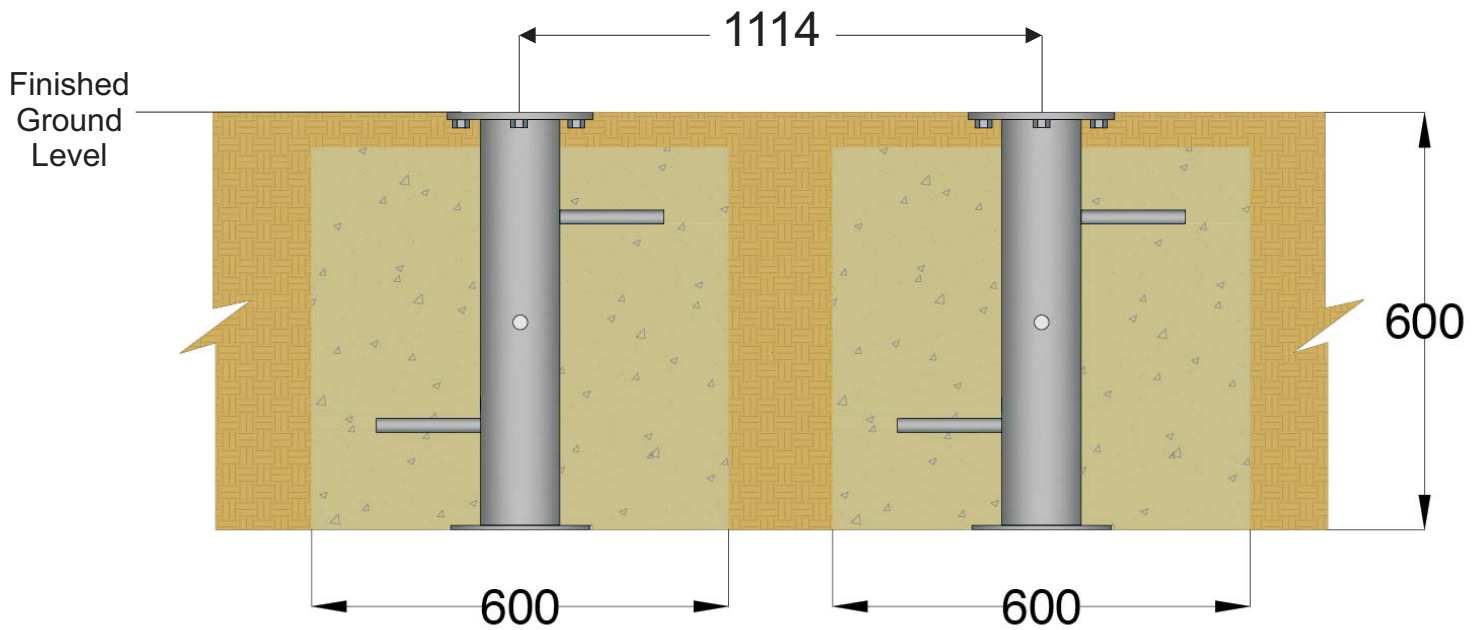

2no holes  
600 x 600 x 600 deep

## Component List

Ref	Main Parts	Qty
A	Ground Anchor & Base	2
B	Main Post & Pre-assembled Kit	1
C	Captive Nut	N/A
D	M12 Steel Washer	10
E	M12 x 45mm Hexagonal Bolt	8
F	Black Plastic Cap	8
G	M12 x 135mm Hexagonal Bolt	1
H	M12 Cap Set	2
I	76mm Plastic Cap	1
J	M10 x 30mm Hexagonal Bolt	1
K	M10 Steel Washer	1
L	Leg Push Assembly	1
M	Slalom Assembly	1

Post Attachment - repeat for both posts(fig 2)

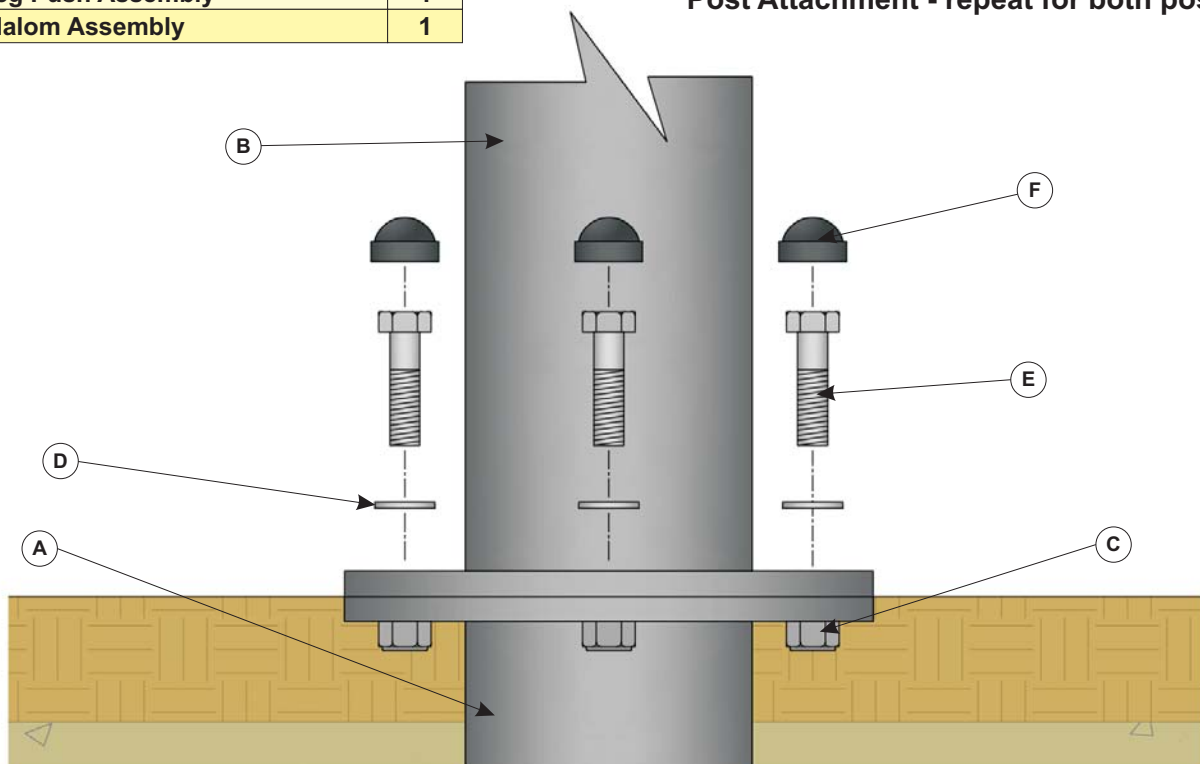

# FZ33 - Zone Leg Workout Combo

## Maintenance & Inspection

If any part of the equipment is found to be unsafe during an inspection and cannot be immediately rectified the equipment should be protected against further use.

## Routine Visual Inspection.

Routine visual inspections are to be conducted to identify obvious hazards resulting from vandalism, use or weather conditions. e.g. Hazards such as broken parts or broken bottles.

## Operational Inspection.

To reduce accidents the operator should ensure an appropriate routine maintenance schedule is established, implemented and maintained. Inspection shall be carried out on a monthly basis, although consideration should be taken regarding local conditions and usage.

During a operational inspection the following should be included:

- Tightening of fastenings.
- Re-painting and re-treatment of surfaces.
- Maintenance of any impact attenuating surfaces.
- Marking of equipment to signify loose fill finished surface levels.
- Cleaning.
- Removal of broken glass and other debris or contaminants.
- Restoring loose fills to the correct level.
- Maintenance of free space areas.

## Annual Main Inspection (NOT EXCEEDING 12 MONTHS)

Inspection intended to establish the overall level of safety of equipment, foundation and playing surfaces.

Effects of weather.

Rotting or corrosion.

A change in the level of safety of the equipment as a result of repairs made, or of added or replaced components

## Corrective Maintenance.

Corrective maintenance should include measures to correct defects, or to-establish the necessary levels of safety of the playground equipment and surfaces. Such measures should include:

- Replacement of fastenings.
- Welding or welding repairs.
- Replacement of worn or defective parts.
- Replacement of defective structural components.

## Equipment Alterations.

Alterations to parts that could affect the essential safety of the equipment should only be carried out after consultation with Play and Leisure.

## Equipment Identification

Information regarding the manufacturer, I.D. Number, year of manufacturer and the European Standard is displayed on a plaque

Issue. No.  Created By:  Date:  Signed:

Issue. No.  Created By:  Date:  Signed:

Issue. No.  Created By:  Date:  Signed: