

## Material & Product Details

**Steel** sections are all mild steel to the relevant BS EN steel standards

**Plastic** panels are made from long lasting HDPE

**Chains** are 8mm short link sherardised mild steel

**Fixings** are mostly BZP, high tensile steel, hex head bolts with washers and Nyloc nuts

## Coatings

All steel equipment made by Play & Leisure is shotblasted to SA 2.5 before a 60-micron thick epoxy-based zinc phosphate primer is applied and finally a 70 micron thick coating of polyester powder.

All Play & Leisure Ltd's equipment & surfacing complies to BS EN 1176 parts 1-10, BS EN 1177 and BS EN 15312. Equipment is guaranteed for 30 years against structural failure.



## Installation Instructions

1. Mark our holes as per Figure 1
2. Excavate holes as per Figure 2
3. Fit the Posts into the excavated holes and connect together using the various components with M10 x 30 Resistorx Bolts & Nylon Washes (Tap holes with a 10mm tap)
4. Once all equipment is fitted, check levels again, tighten all bolts and concrete into the ground

***Do not leave unattended until satisfied the concrete has cured or the site is secure.***

## Hole Layout (fig. 1)

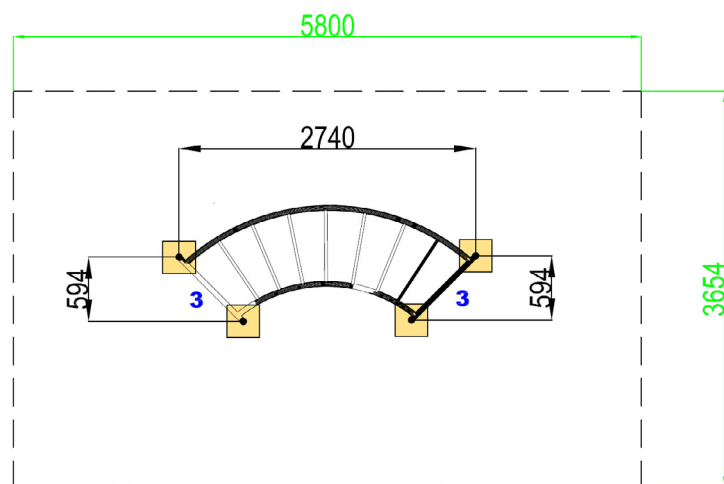

## Foundation Detail (fig. 2)

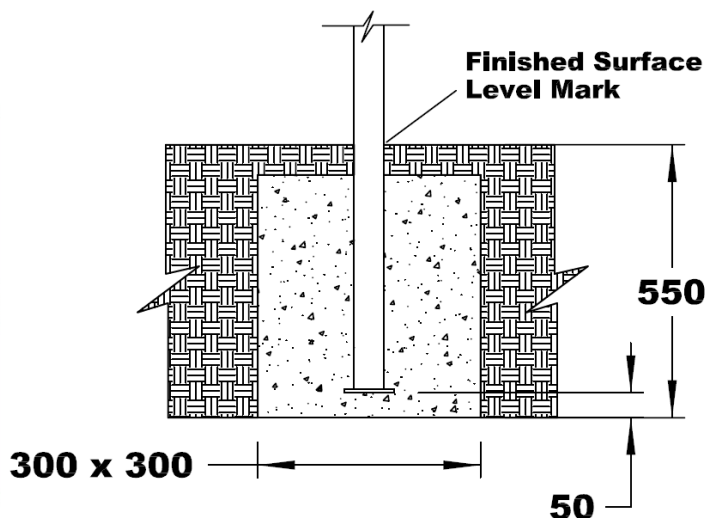



 All Play & Leisure's product range is fully compliant with **BS EN 16630**

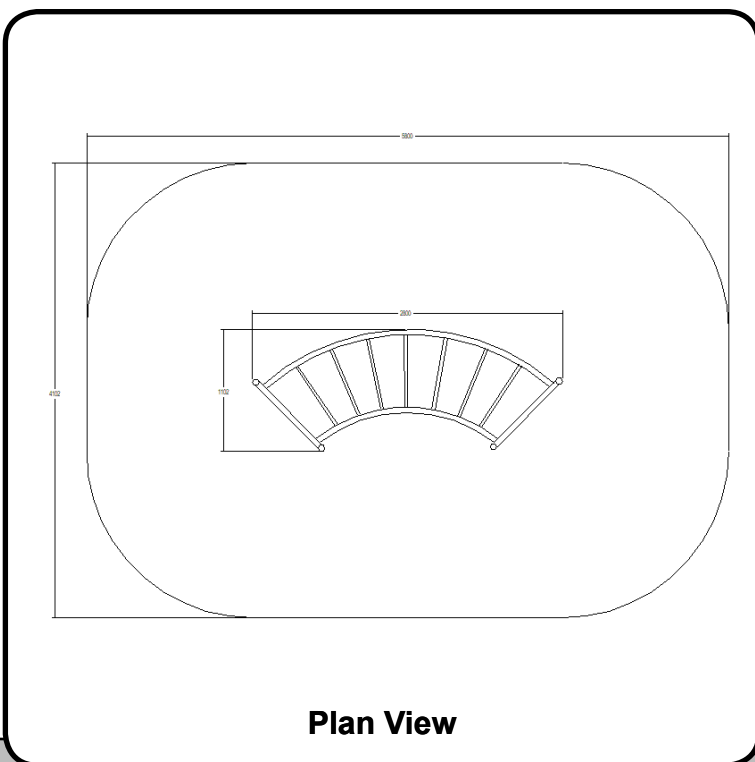

**Plan View**

## Technical Information

**Product Code**

*FZ102*

**Equipment Size**

*2800L x 1102W x 2300H*

**Minimum Space**

*4102 x 5800*

**Exercise Type**

*Stretch & Toning*

# Play & Leisure Ltd

## Maintenance Schedule

### **Maintenance & Inspection**

All Play & Leisure's products should be inspected and maintained in accordance with the recommendations as detailed in BS EN 1176-7:2008

If any part of the equipment is found to be unsafe during an inspection and cannot be immediately rectified the equipment should be protected against further use.

### **Routine Visual Inspection.**

Routine visual inspections are to be conducted to identify obvious hazards resulting from vandalism, use or weather conditions. e.g. Hazards such as broken parts or broken bottles.

### **Operational Inspection.**

To reduce accidents the operator should ensure an appropriate routine maintenance schedule is established, implemented and maintained. Inspection shall be carried out on a monthly basis, although consideration should be taken regarding local conditions and usage.

During a operational inspection the following should be included:

- Tightening of fastenings.
- Re-painting and re-treatment of surfaces.
- Maintenance of any impact attenuating surfaces.
- Lubrication of bearings.
- Marking of equipment to signify loose fill finished surface levels.
- Cleaning.
- Removal of broken glass and other debris or contaminants.
- Restoring loose fills to the correct level.
- Maintenance of free space areas.

### **Annual Main Inspection (NOT EXCEEDING 12 MONTHS)**

Inspection intended to establish the overall level of safety of equipment, foundation and playing surfaces.

- Effects of weather.
- Rotting or corrosion.
- A change in the level of safety of the equipment as a result of repairs made, or of added or replaced components

### **One Post Equipment Maintenance.**

Special attention should be paid to the stability of products being of a one post design.

### **Corrective Maintenance.**

Corrective maintenance should include measures to correct defects, or to establish the necessary levels of safety of the playground equipment and surfaces. Such measures should include:

- Replacement of fastenings.
- Welding or welding repairs.
- Replacement of worn or defective parts.
- Replacement of defective structural components.

### **Equipment Alterations.**

Alterations to parts of any products that could affect the essential safety of the equipment should only be carried out after consultation with Play and Leisure.

### **Equipment Identification**

Information regarding the manufacturer, I.D. Number, year of manufacturer and the European Standard is displayed on an identification plaque.