

SIDE

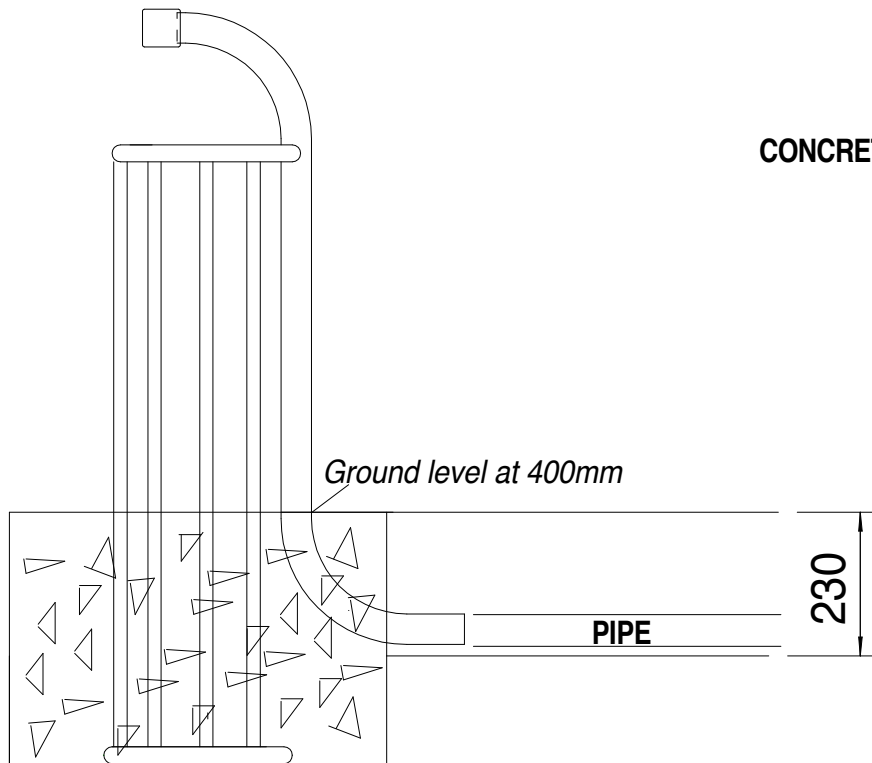

PLAN

500

CONCRETE

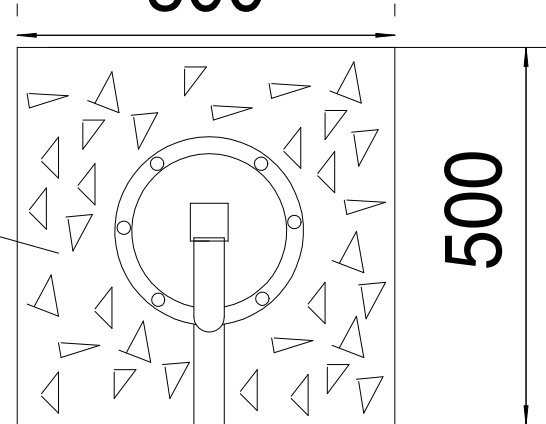

500

KEY



CONCRETE



SOIL, STONE OR TARMAC

100

Notes:

<sup>3</sup> FOUNDATIONS: APPROX 0.3M OF CONCRETE REQUIRED

INSTALLATION: 2 MEN @ 3 HOUR



✓ All Play & Leisure's product range is fully compliant with **BS EN 1176:2008**

| Technical AT-A-GLANCE |
|-----------------------|
| Product Code          |
| ETTS1                 |
| Equipment Size        |
| 300L x 300W x 720H    |

Side Elevation

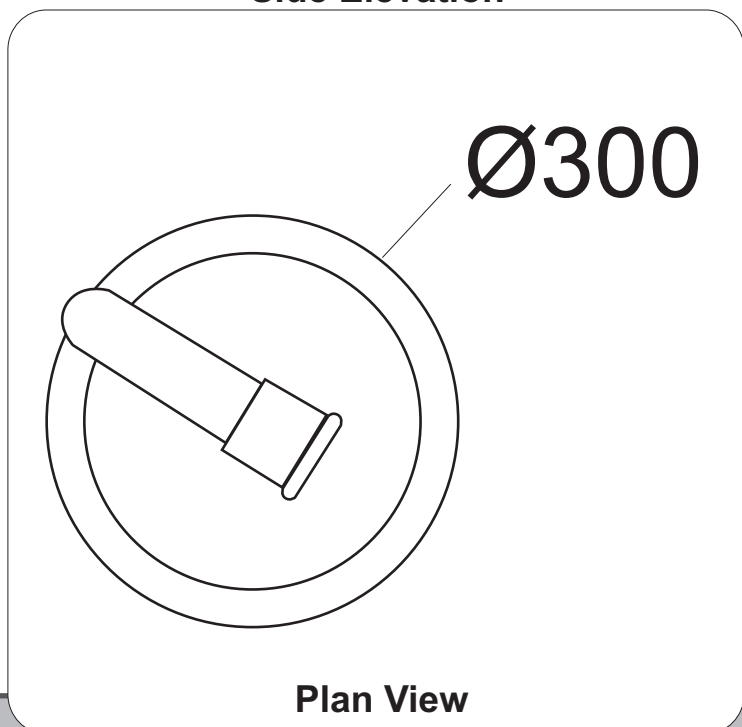

# Maintenance Schedule

## **Maintenance & Inspection**

All Play & Leisure's products should be inspected and maintained in accordance with the recommendations as detailed in BS EN 1176-7:2008

If any part of the equipment is found to be unsafe during an inspection and cannot be immediately rectified the equipment should be protected against further use.

## **Routine Visual Inspection.**

Routine visual inspections are to be conducted to identify obvious hazards resulting from vandalism, use or weather conditions. e.g. Hazards such as broken parts or broken bottles.

## **Operational Inspection.**

To reduce accidents the operator should ensure an appropriate routine maintenance schedule is established, implemented and maintained. Inspection shall be carried out on a monthly basis, although consideration should be taken regarding local conditions and usage.

During a operational inspection the following should be included:

- Tightening of fastenings.
- Re-painting and re-treatment of surfaces.
- Maintenance of any impact attenuating surfaces.
- Lubrication of bearings.
- Marking of equipment to signify loose fill finished surface levels.
- Cleaning.
- Removal of broken glass and other debris or contaminants.
- Restoring loose fills to the correct level.
- Maintenance of free space areas.

## **Annual Main Inspection (NOT EXCEEDING 12 MONTHS)**

Inspection intended to establish the overall level of safety of equipment, foundation and playing surfaces.

- Effects of weather.
- Rotting or corrosion.
- A change in the level of safety of the equipment as a result of repairs made, or of added or replaced components

## **One Post Equipment Maintenance.**

Special attention should be paid to the stability of products being of a one post design.

## **Corrective Maintenance.**

Corrective maintenance should include measures to correct defects, or to establish the necessary levels of safety of the playground equipment and surfaces. Such measures should include:

- Replacement of fastenings.
- Welding or welding repairs.
- Replacement of worn or defective parts.
- Replacement of defective structural components.

## **Equipment Alterations.**

Alterations to parts of any products that could affect the essential safety of the equipment should only be carried out after consultation with Play and Leisure.

## **Equipment Identification**

Information regarding the manufacturer, I.D. Number, year of manufacturer and the European Standard is displayed on an identification plaque.