

# Balance Weave

General Information - Page 1 of 2

Revision - 0  
Saved Date 20 July 2017 12:13:37

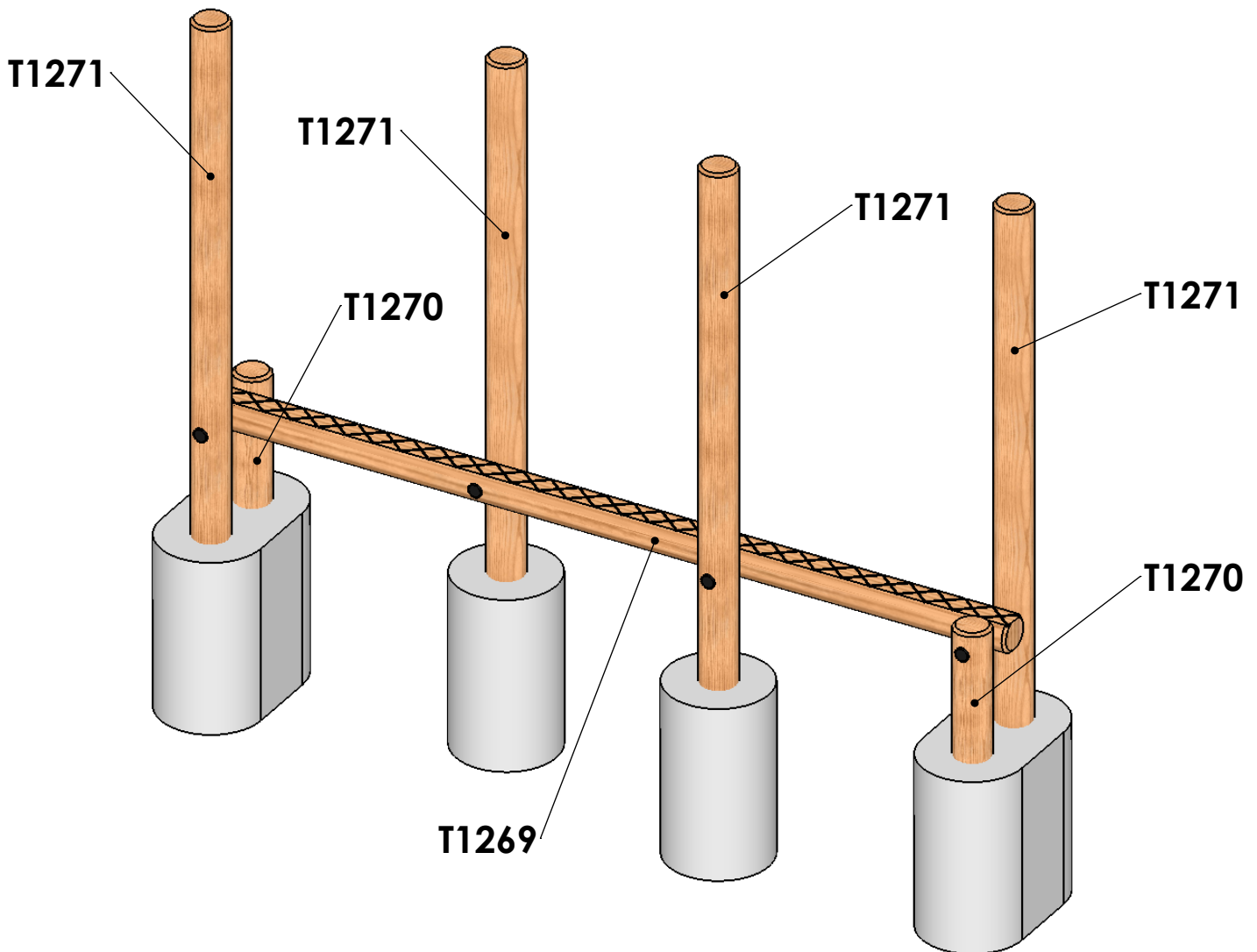

ITEM NO.	PART NUMBER	DESCRIPTION	Default/QTY.
1	T1269	Timber 125mm dia. cut at 2800mm DC	1
2	T1270	Timber 125mm dia. cut at 1050mm SC	2
3	T1271	Timber 125mm dia. cut at 2400mm SC	4



Statement of Compliance: AE Evans Ltd. manufacturers of children's playground equipment follow the codes and practices outlined in the British and European Standards. By doing this, all equipment for play areas manufactured by AE Evans meets the requirements of BSEN 1176 (general safety and test methods). Spares can be supplied via equipment distributor.

# Balance Weave

Excavation details - Page 2 of 2

Revision - 0  
Saved Date 20 July 2017 12:13:37

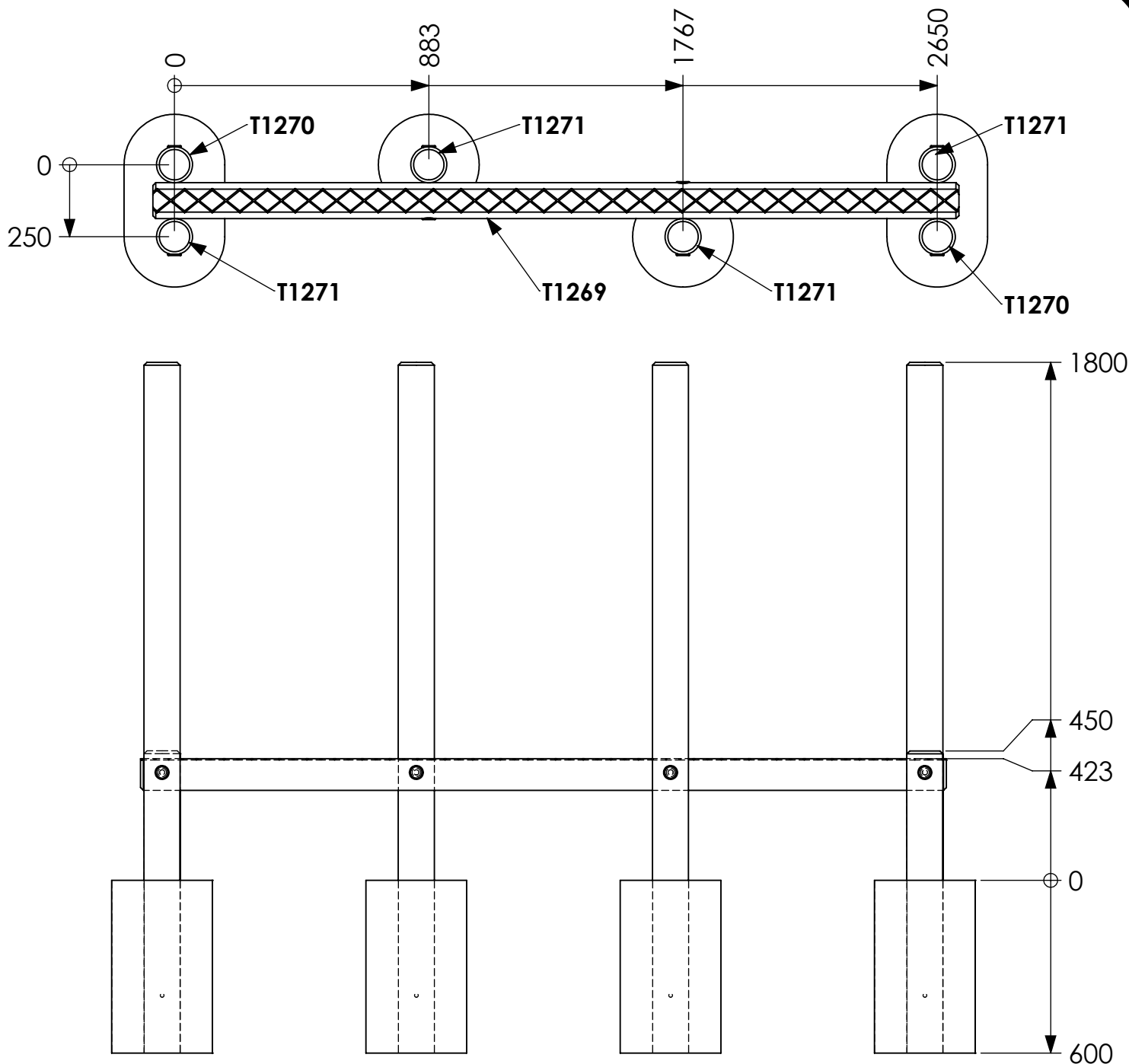

**Dig groundworks 600mm deep**

**FFH: 450mm**

No safety surface required as critical fall height is less than 600mm. However we suggest allowing an appropriate free space around the item in compliance with BS EN1176.

## Bolt List

- 02 No M16 x 320mm Hex Bolts
- 02 No M16 x 200mm Hex Bolts
- 08 No M16 Washers
- 04 No M16 Nylock Nuts
- 08 No 40mm Black Inserts

**Please note additional fixings are included therefor you may have some left over.**



Statement of Compliance: AE Evans Ltd. manufacturers of children's playground equipment follow the codes and practices outlined in the British and European Standards. By doing this, all equipment for play areas manufactured by AE Evans meets the requirements of BSEN 1176 (general safety and test methods). Spares can be supplied via equipment distributor.