

Balance Walk

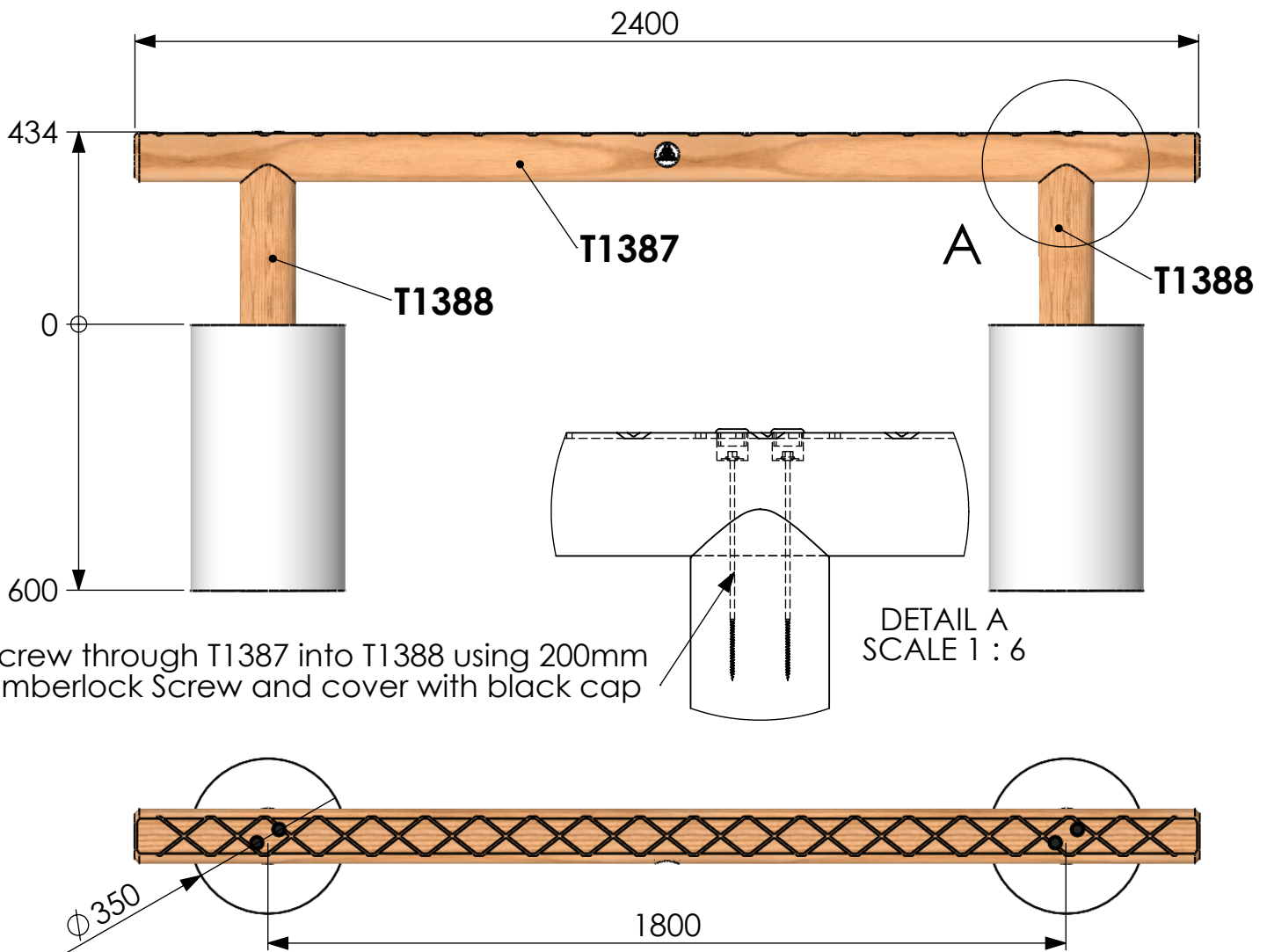

ITEM NO.	PART NUMBER	DESCRIPTION	QTY
1	T1387	Timber 125mm dia. cut at 2400mm DC	1
2	T1388	Timber 125mm dia cut at 965mm	2

Bolt List

04 No 6.5 x 200mm Timberlock Screw
01 No Drive bit for above bolts
04 No M8 Washers
04 No 25mm Black Inserts

Dig all groundworks 600mm deep

FFH = 0.434m

No safety surface required as critical fall height is less than 600mm.
However we suggest allowing an appropriate free space around the item in compliance with BS EN1176.



