

Play & Leisure Ltd

Installation Details For Medway River multiplay (R104)

<u>Component List</u>	<u>Quantity</u>
1.0m H Sections	4
Platforms	2
Semi-Circular Inc. Barrier	1
Access Steps	1
1.0m Single Slide, holder & foot	1
Shop Counter Play Panel	1
Crawl Tube	1
Fireman's Pole	1
Grab Bar Handles	1
Steering Wheel Panel	1
Binoculars	1
Climb Wall Panel	1

- 1 Construct base as per layout drawing 1 ensuring the correct levels for safety surfacing.
- 2 Excavate 400mm x 400mm holes for H Sections as in drawing 2 to a depth of 400mm from finished safety surfacing height. (All H sections ARE NUMBERED & have finished ground level marks)
- 3 Assemble the H sections together in pairs as per drawing 2 with a platform using M10 x 30 resistorx & nylon washers. (**Tap holes with a 10mm tap and make sure bolts are only hand tight at this stage**)
- 4 Fit the H sections into the excavated holes and connect together using the stated links ie. Monkey Walk.
- 5 When all H sections have been fitted, level in all directions and check distances from edge of surfacing area
- 6 Mark out for access points as drawing 3 and excavate to a depth of 400 as before (**550 for the slide foot**)
- 7 Assemble all other items of equipment as drawing 4 using M10 x 30 resistorx & nylon washers
- 8 Note. M10 x 25 resistorx are used to connect the slide to the foot
- 9 Once all equipment is fitted check levels again, tighten all bolts and concrete into the ground
- 10 Use M10 x 50 Resistorx & bolt caps for the play panels

Note: Do not leave unattended until satisfied the concrete has cured or the site is secure

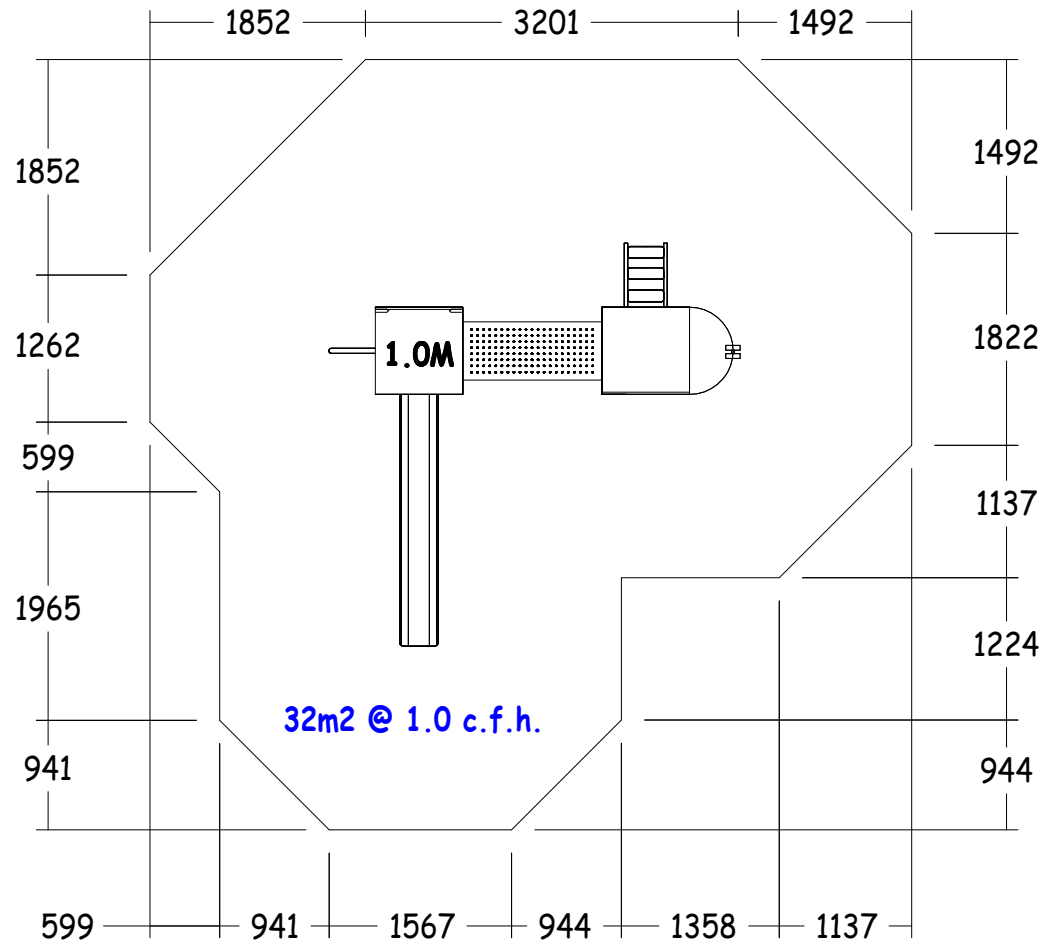

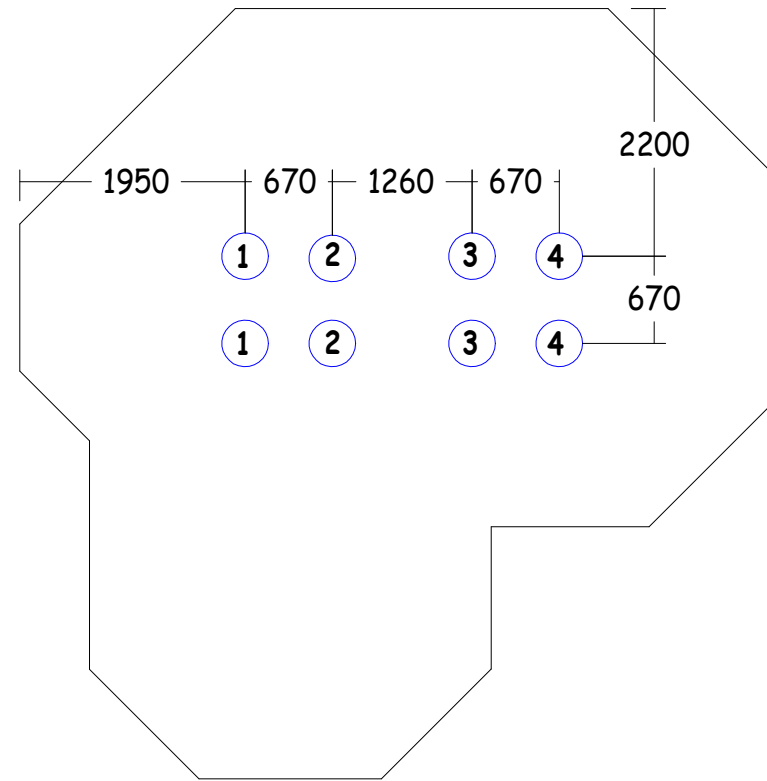

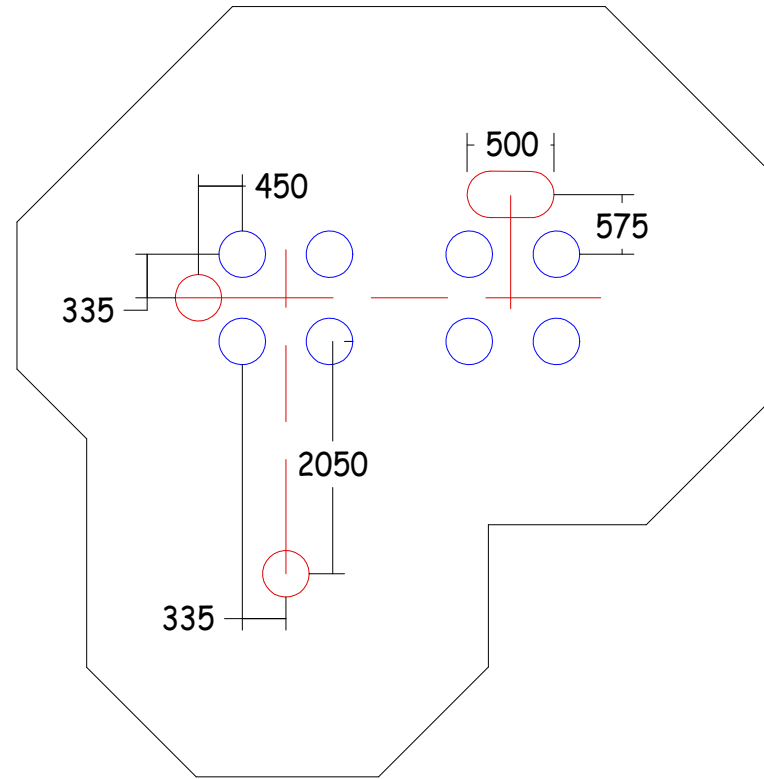

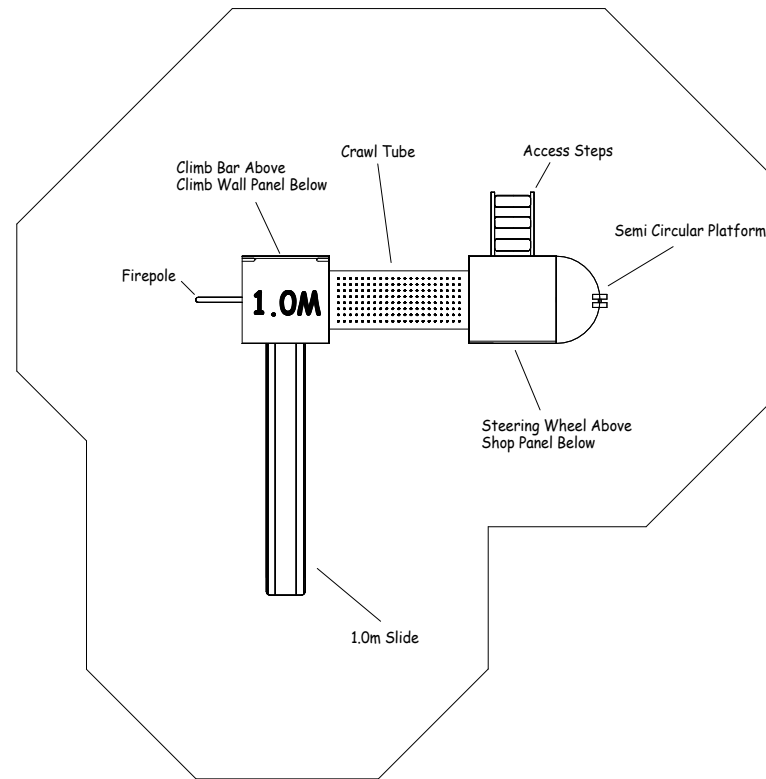



✓ All Play & Leisure's product range is fully compliant with **BS EN 1176**

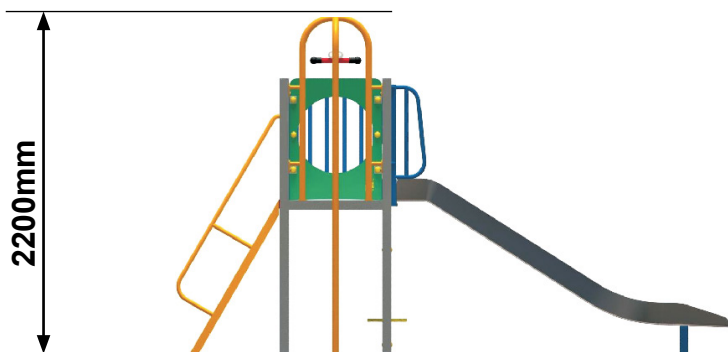
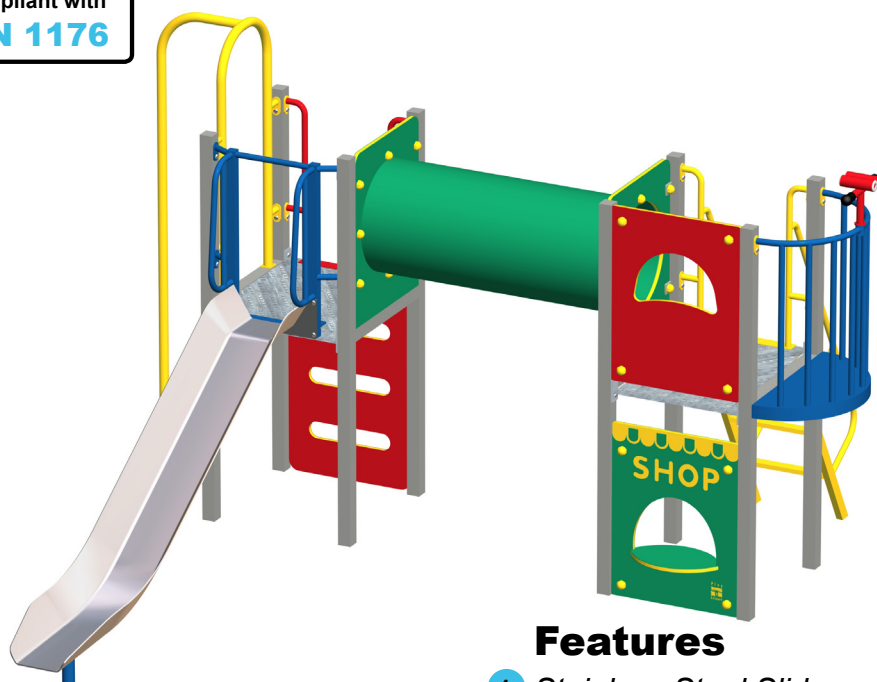

Side Elevation

Features

- 1 Stainless Steel Slide
- 2 Access Steps
- 3 Binoculars
- 4 Climb Wall
- 5 Fireman's Pole
- 6 Crawl Tube
- 7 Shop Play Panel
- 8 Steering Wheel Play Panel
- 9 Semi-Circular Barrier
- 10 Grab Bar Handles

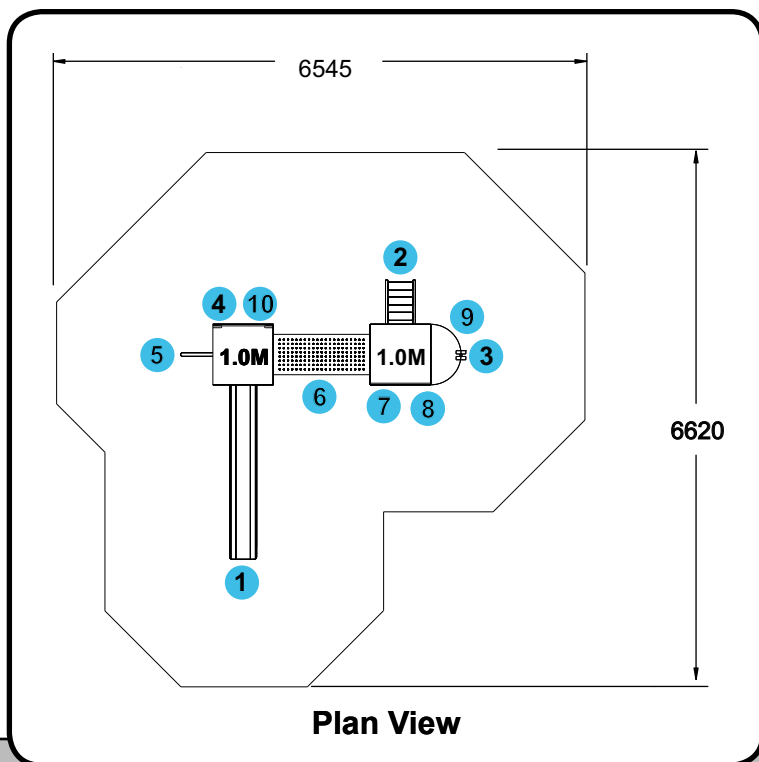

Plan View

Technical Information

Product Code	R104
Equipment Size (mm)	3475L x 3461W x 2200H
Minimum Space (mm)	6545 x 6620
Free Height of Fall (mm)	1000
Safety Surface Area	32m ²
User Age Range	2-5 Years

Play & Leisure Ltd

Maintenance Schedule

Maintenance & Inspection

All Play & Leisure's products should be inspected and maintained in accordance with the recommendations as detailed in BS EN 1176-7:2008

If any part of the equipment is found to be unsafe during an inspection and cannot be immediately rectified the equipment should be protected against further use.

Routine Visual Inspection.

Routine visual inspections are to be conducted to identify obvious hazards resulting from vandalism, use or weather conditions. e.g. Hazards such as broken parts or broken bottles.

Operational Inspection.

To reduce accidents the operator should ensure an appropriate routine maintenance schedule is established, implemented and maintained. Inspection shall be carried out on a monthly basis, although consideration should be taken regarding local conditions and usage.

During a operational inspection the following should be included:

- Tightening of fastenings.
- Re-painting and re-treatment of surfaces.
- Maintenance of any impact attenuating surfaces.
- Lubrication of bearings.
- Marking of equipment to signify loose fill finished surface levels.
- Cleaning.
- Removal of broken glass and other debris or contaminants.
- Restoring loose fills to the correct level.
- Maintenance of free space areas.

Annual Main Inspection (NOT EXCEEDING 12 MONTHS)

Inspection intended to establish the overall level of safety of equipment, foundation and playing surfaces.

- Effects of weather.
- Rotting or corrosion.
- A change in the level of safety of the equipment as a result of repairs made, or of added or replaced components

One Post Equipment Maintenance.

Special attention should be paid to the stability of products being of a one post design.

Corrective Maintenance.

Corrective maintenance should include measures to correct defects, or to establish the necessary levels of safety of the playground equipment and surfaces. Such measures should include:

- Replacement of fastenings.
- Welding or welding repairs.
- Replacement of worn or defective parts.
- Replacement of defective structural components.

Equipment Alterations.

Alterations to parts of any products that could affect the essential safety of the equipment should only be carried out after consultation with Play and Leisure.

Equipment Identification

Information regarding the manufacturer, I.D. Number, year of manufacturer and the European Standard is displayed on an identification plaque.