

Vortex Rotator

QU91

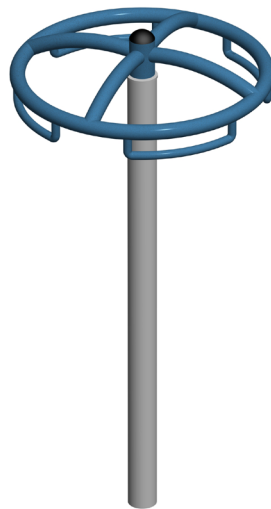

7+



4



8hrs



500



20

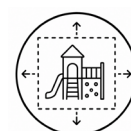

5mx5m

The Vortex Rotator from Play and Leisure Ltd is a compact yet exciting playground spinner that delivers fast-paced fun and active play. Designed for children to grip the circular handrail and rotate around the central axis, it helps develop balance, coordination, core strength, and spatial awareness while encouraging confidence through movement. Its durable, low-maintenance construction and space-efficient design make it an excellent addition to any playground, providing endless spinning fun in a simple, robust, and engaging play feature.

Key



Age Range



Number Of Users



Assembly Time



Free Fall Height



Impact Area



Wheelchair Accessible



Space Needed



For All Users

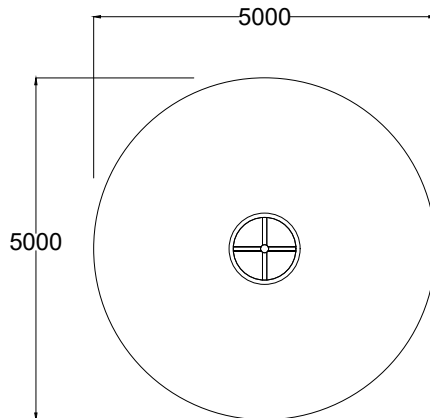

Specification	
Age Range:	7+ Years
Safety Area Width (mm):	5000
Safety Area Length (mm):	5000
Safety Area (m ²):	20
Free Fall Height (mm):	500
Assembly Time:	8 hrs
People For Installation:	2

There shall be an additional area with a length of 500mm in the rotating direction (All Around) free from obstacles.



Hot-Dip Galvanising
Optional Extra



Inclusive Information

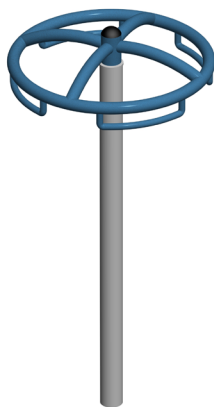

WORKING TOGETHER



COMMUNICATING



SHARING



IMAGINATION

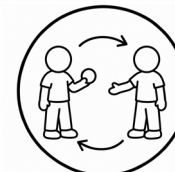

TURN-TAKING



SPINNING AND ROLLING

Guaranteed for product lifetime against structural failure



Guaranteed for 5 years

Guaranteed for 5 years



Guaranteed for 8 years

Guaranteed for 10 years



Guaranteed for 2 years

Guaranteed for 2 years



Guaranteed for 1 year

Play Panels + HDPE Products



For consumable parts:
- Beaters
- Cables



For electronic failure caused by manufacturing defects in:
- Speakers
- Sound chips
- Circuit boards



For mechanical failure caused by faulty workmanship or material defects in:
- Moving parts
- Standing and heavy duty springs



For defects resulting from the manufacture of:
- High density polyethylene sheets
- Structural steel components