

Bee

ESS31



3+



2



2hrs



780



19.5



4.56mx4.24m

The Bee Spring Seesaw from Play and Leisure Ltd combines playful character design with exciting, active movement to create a truly engaging playground experience. Featuring a cheerful bee theme and spring-mounted action, it encourages children to work together while developing balance, coordination, and confidence. The dynamic rocking motion adds an extra level of fun to this modern take on a traditional seesaw, while the bright, friendly design sparks imagination and encourages social play. Built from durable, low-maintenance materials and manufactured to the highest safety standards, the Bee Spring Seesaw is a vibrant addition to any playground.

Key



Age Range



Number Of Users



Assembly Time



Free Fall Height



Impact Area



Wheelchair Accessible



Space Needed



For All Users

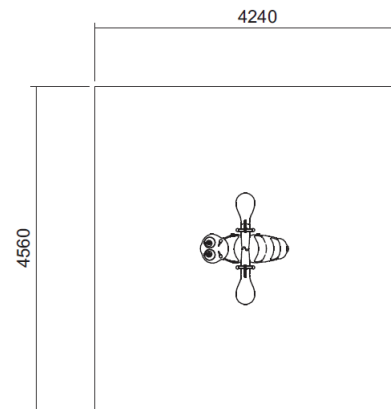
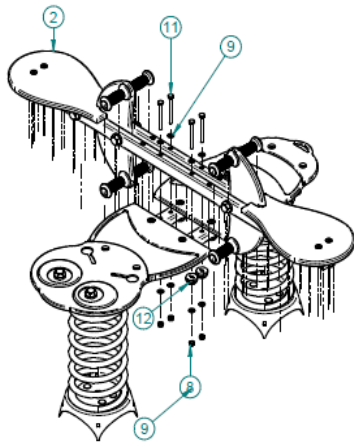

Specification	
Age Range:	3+ Years
Safety Area Width (mm):	4560
Safety Area Length (mm):	4240
Safety Area (m ²):	19.5
Free Fall Height (mm):	780
Assembly Time:	2 hrs
People For Installation:	1



Hot-Dip Galvanising
Optional Extra



Inclusive Information



WORKING TOGETHER



COMMUNICATING



SHARING



IMAGINATION

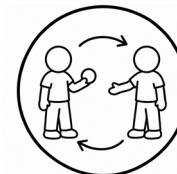

TURN-TAKING



SWINGING / ROCKING

Guaranteed for product lifetime against structural failure



Guaranteed for 5 years

Guaranteed for 5 years



Guaranteed for 8 years

Guaranteed for 10 years



Guaranteed for 2 years

Guaranteed for 2 years



Guaranteed for 1 year

Play Panels + HDPE Products



For consumable parts:
- Beaters
- Cables



For electronic failure caused by manufacturing defects in:
- Speakers
- Sound chips
- Circuit boards



For mechanical failure caused by faulty workmanship or material defects in:
- Moving parts
- Standing and heavy duty springs



For defects resulting from the manufacture of:
- High density polyethylene sheets
- Structural steel components