

**Octopus**  
ESS30

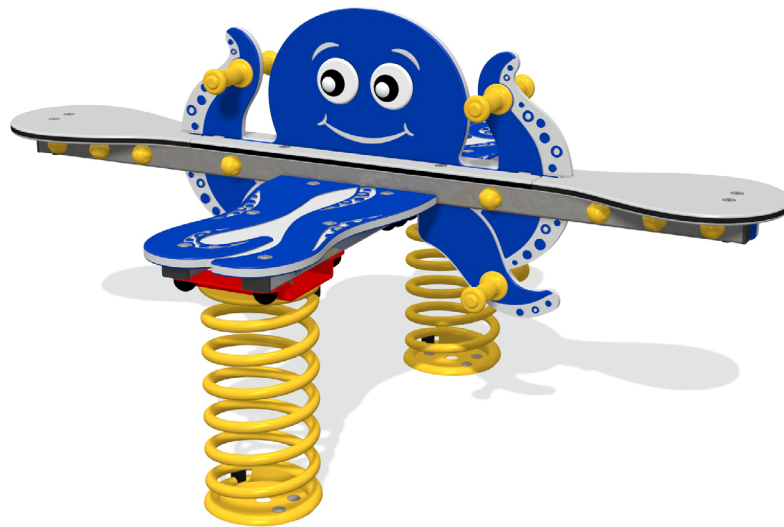

**3+**



**2**



**2hrs**



**780**



**19**

**4.56mx4.16m**



The Octopus Spring Seesaw from Play and Leisure Ltd combines imaginative ocean-themed design with exciting, interactive play. Featuring a friendly octopus character and a unique spring-mounted platform, it delivers dynamic movement that helps children develop balance, coordination, and confidence while having fun. Designed for multiple users, it encourages social interaction, cooperation, and shared play experiences, making it an engaging and inclusive addition to any playground. Built from durable, low-maintenance materials and manufactured to the highest safety standards, the Octopus Spring Seesaw provides years of active play and adventure.

**Key**



Age Range



Number Of Users



Assembly Time



Free Fall Height



Impact Area



Wheelchair Accessible



Space Needed



For All Users

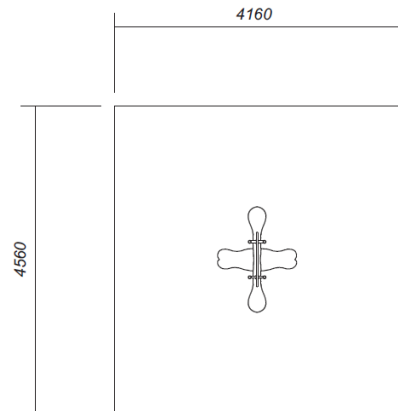
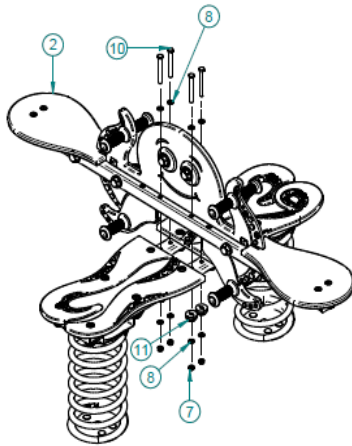

Specification	
Age Range:	3+ Years
Safety Area Width (mm):	4560
Safety Area Length (mm):	4160
Safety Area (m <sup>2</sup> ):	19
Free Fall Height (mm):	787
Assembly Time:	2 hrs
People For Installation:	1



Hot-Dip Galvanising  
Optional Extra



## Inclusive Information



WORKING TOGETHER



COMMUNICATING



SHARING



IMAGINATION

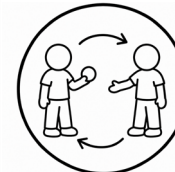

TURN-TAKING



SWINGING / ROCKING

Guaranteed for product lifetime against structural failure



Guaranteed for 5 years

Guaranteed for 5 years



Guaranteed for 8 years

Guaranteed for 10 years



Guaranteed for 2 years

Guaranteed for 2 years



Guaranteed for 1 year

**Play Panels + HDPE Products**



For consumable parts:  
- Beaters  
- Cables



For electronic failure caused by manufacturing defects in:  
- Speakers  
- Sound chips  
- Circuit boards



For mechanical failure caused by faulty workmanship or material defects in:  
- Moving parts  
- Standing and heavy duty springs



For defects resulting from the manufacture of:  
- High density polyethylene sheets  
- Structural steel components