

FSCURVIN - Curve Sit-In Spring Rocker Installation Guide

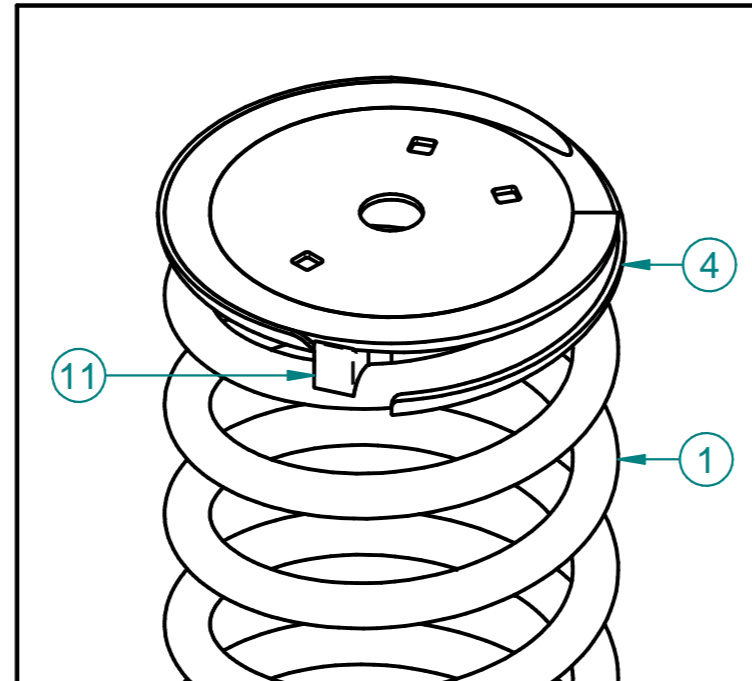
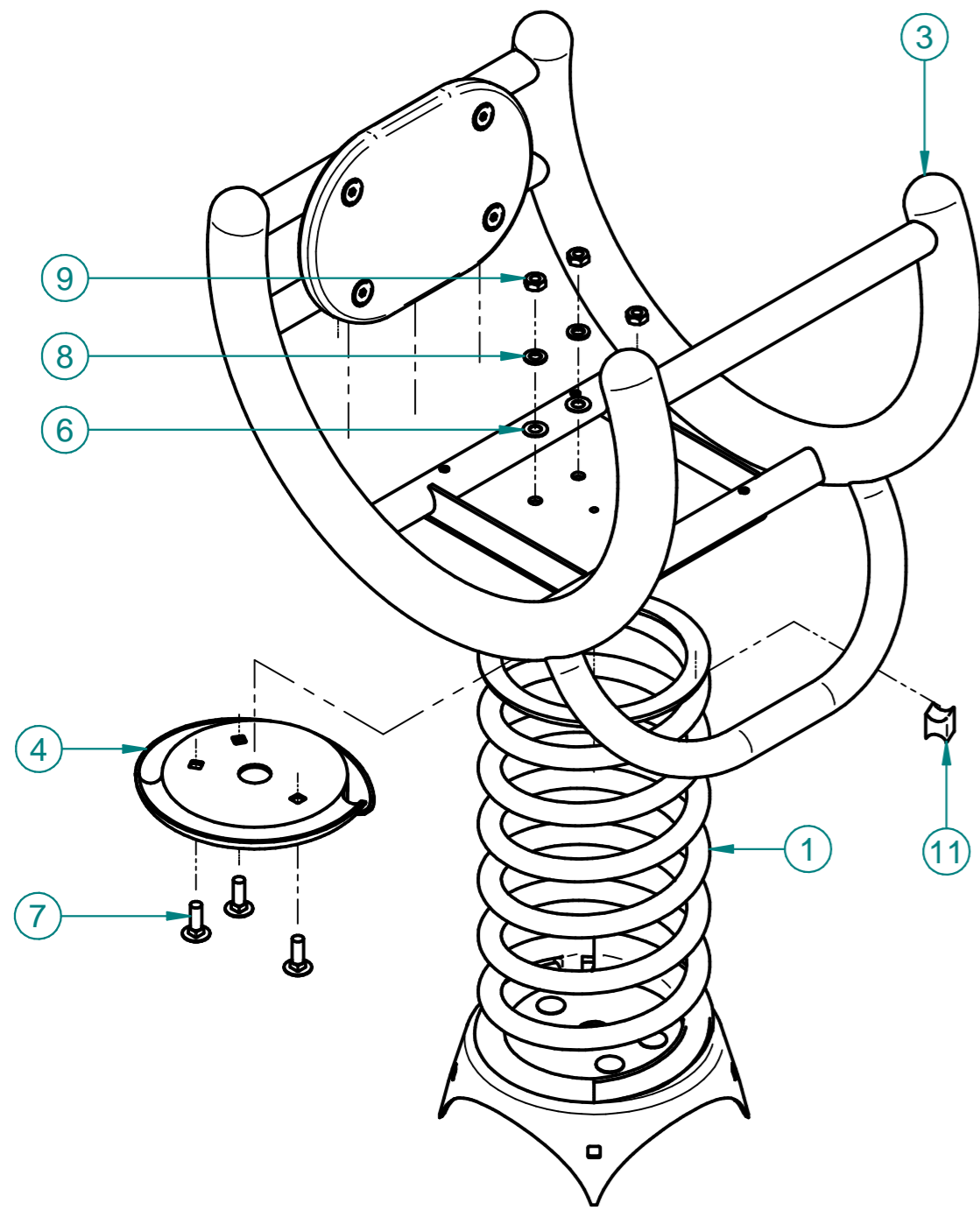
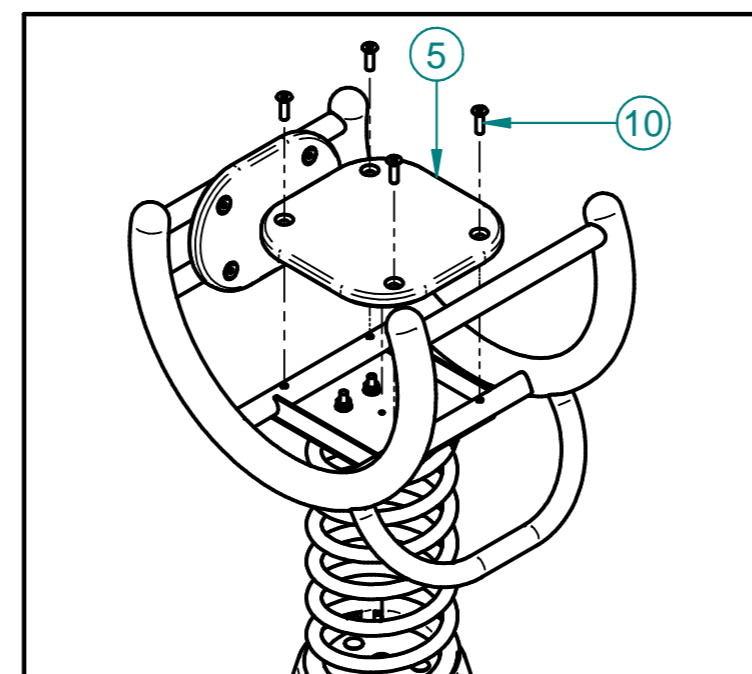

fig. 1

Before positioning Spring Mounting Plate, place the Spring Spacer in situ as shown above. Ensure Spring Mounting Plate is then sitting correctly before securing to Sit-In Springer Frame.



3. Bolt the Springer Seat over the Fixings used in step 2 as shown above.

4. Assemble Ground Anchor and bolt to the bottom bracket of the pre-assembled spring.

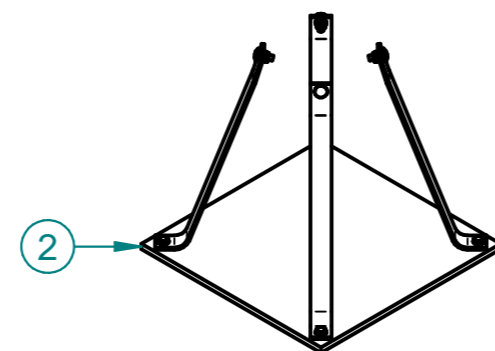

Ground Anchor kit supplied as loose components with fixing pack and instructions.

Please refer to document:
FI-GA-GI-2013-A EGA Ground Anchor Installation Guide for specific footing details.

This product should be inspected by a competent person who is familiar with BS EN 1176 to the below maintenance and inspection schedule.

Maintenance Inspection

FREQUENCY	WHAT TO DO
VISUAL INSPECTION (EVERY MONTH)	Identify any risks stemming from vandalism, intensive use or unusual weather
	Check for missing or broken parts
	Make sure that all protective covers are in place
FUNCTIONALITY INSPECTION (EVERY MONTH)	Inspect surfacing below and around equipment
	Check that the equipment, or the part concerned is operating correctly
	Check all fixings, joints and stability of the equipment and tighten or replace if necessary
COMPREHENSIVE INSPECTION (EVERY 6 MONTHS)	Check all parts for wear and tear and replace if necessary
	Thorough cleaning of equipment and any stainless steel parts with water and detergent
	All of the above plus:
	Inspect the anchoring system
COMPREHENSIVE INSPECTION (EVERY 6 MONTHS)	Inspect any moving, mechanical and electrical parts are operating correctly
	Check overall condition of any paintwork or galvanizing – repaint / touch up if necessary

Surfacing Area: 7.6 sqm
Free Height of Fall: 0.45m

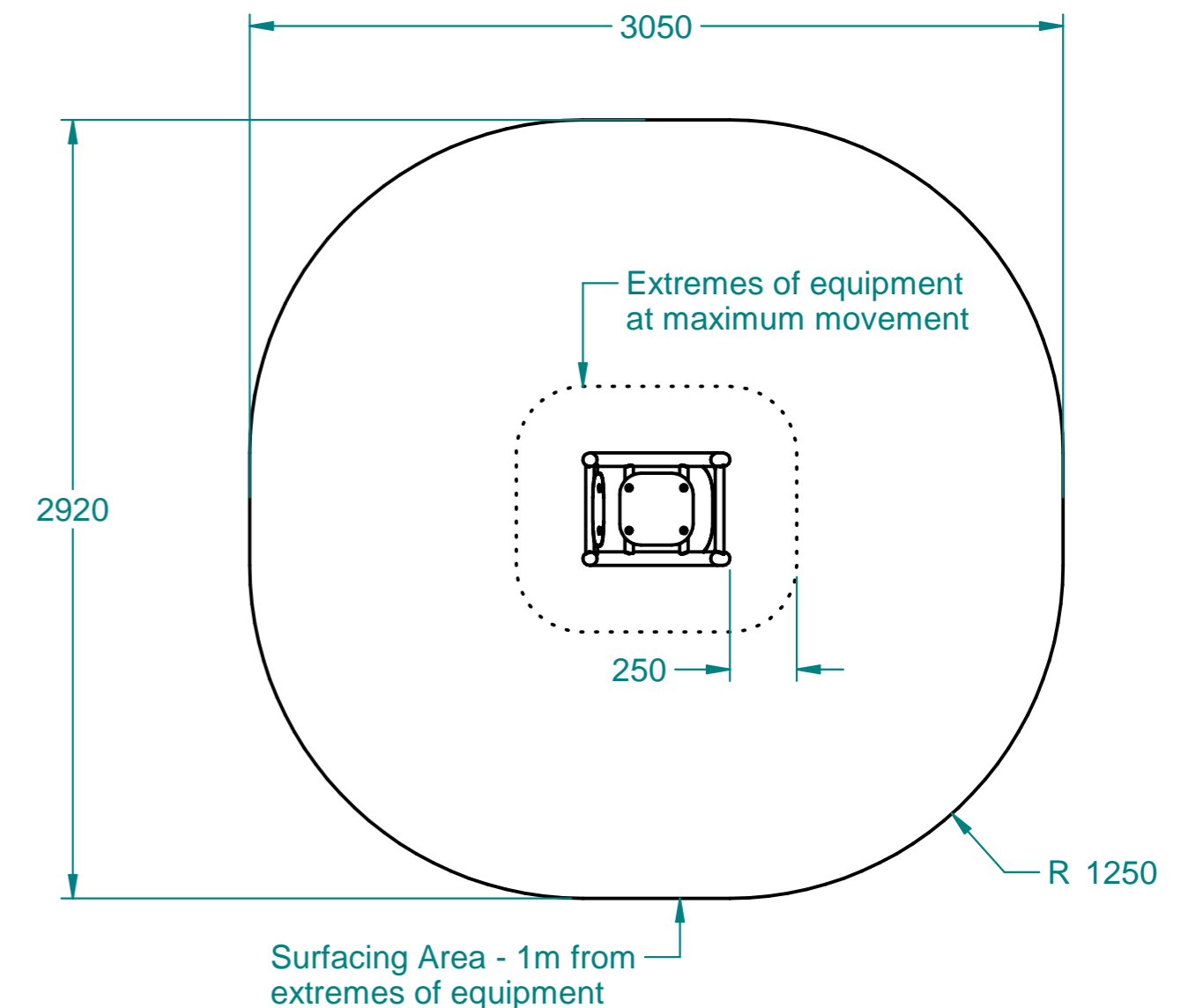

Parts List

Item	Code	Description	Qty
1		400mm Spring Assembly	1
2		Ground Anchor Kit	1
3		Curve Sit-In Springer Frame Assembly	1
4	FME0013-A	Spring Mounting Plate	1
5	FPL3114-B	Curve Sit-In Springer Seat	1
6	FSU0031-A	M10 Washer - SS	3
7	FSU0065-A	M10 x 30mm Coach Bolt - SS	3
8	FSU0096-A	M10 Locking Washer - SS	3
9	FSU0097-A	M10 Plain Nut - SS	3
10	FSU0197-A	M10 x 35mm CSK Bolt - SS	4
11	FSU0304-A	Spring Spacer - Standard - 20 x 25 x 18.5	1



Approx. Unit Weight: 35.5kg

Sit-In Springer Frame Assembly: 13kg
Sit-In Springer Seat: 1.5kg
Spring Assembly: 18kg
Ground Anchor Kit: 3kg

Modification	Date	Approved
New Drawing	27/04/16	RW
Component List Updated	02/08/16	RW

Spitfire Road, Old Sarum, Salisbury
Wiltshire, SP4 6GB, UK
Tel: +44 (0)1722 349 793
www.fahr-industries.com

Fahr Industries Ltd

This document, including the copyright therein, is the property of Fahr Industries Ltd and may not be utilised for any purpose or reproduced, or transmitted to any third party without prior written consent.

⊕	All Dimensions in mm	1 of 1	Not To Scale
DrG By	Richard Willstrop	Date	27/04/2016