

**Dog**  
ESA55



**2+**



**1**



**2hrs**



**494**



**6.75**



**2.908mx2.32m**

Dog Springer provides a fun and engaging rocking experience that helps younger children develop balance, coordination, and core strength. The gentle spring movement encourages active play and body awareness, while the friendly dog design sparks imagination and role play. Its simple, accessible design makes it an ideal introduction to dynamic playground equipment for toddlers and young children.

**Key**



Age Range



Number Of Users



Assembly Time



Free Fall Height



Impact Area



Wheelchair Accessible



Space Needed



For All Users

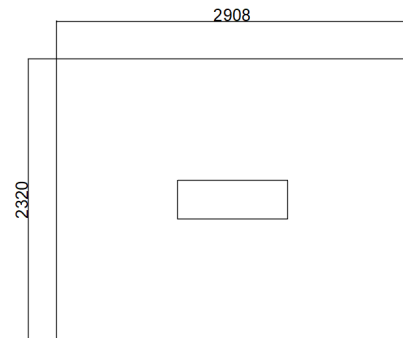
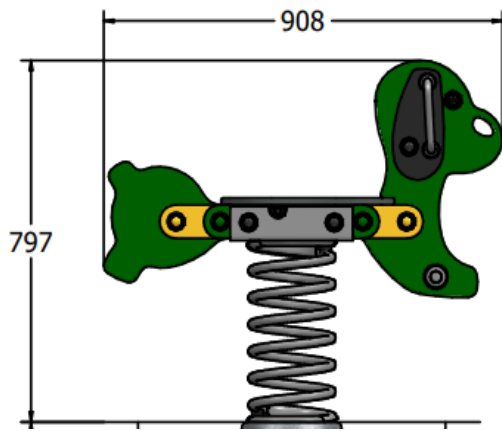

Specification	
Age Range:	2+ Years
Safety Area Width (mm):	2908
Safety Area Length (mm):	2320
Safety Area (m <sup>2</sup> ):	6.75
Free Fall Height (mm):	494
Assembly Time:	2 hrs
People For Installation:	1



Hot-Dip Galvanising  
Optional Extra



## Inclusive Information



IMAGINATION



SHARING

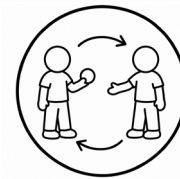

TURN-TAKING



SWINGING / ROCKING

Guaranteed for product lifetime against structural failure



Guaranteed for 5 years

Guaranteed for 5 years



Guaranteed for 8 years

Guaranteed for 10 years



Guaranteed for 2 years

Guaranteed for 2 years



Guaranteed for 1 year

**Play Panels + HDPE Products**



For consumable parts:  
- Beaters  
- Cables



For electronic failure caused by manufacturing defects in:  
- Speakers  
- Sound chips  
- Circuit boards



For mechanical failure caused by faulty workmanship or material defects in:  
- Moving parts  
- Standing and heavy duty springs



For defects resulting from the manufacture of:  
- High density polyethylene sheets  
- Structural steel components