



Twister - ERB01

Steel sections are all mild steel to the relevant BS EN steel standards.

Plastic panels are made from long lasting HDPE and the floor is slip resistant.

Fixings are mostly BZP, high tensile steel, hex head bolts with washers and Nyloc nuts.

Coatings

All steel equipment made by Play & Leisure is shotblasted to SA 2.5 before a 60-micron thick epoxy based zinc phosphate primer is applied and finally a 70 micron thick coating of polyester powder.

All Play & Leisure Ltd's equipment & surfacing complies to BS EN 1176 parts 1-10, BS EN 1177 and BS EN 15312. Equipment is guaranteed for 25 years against structural failure.

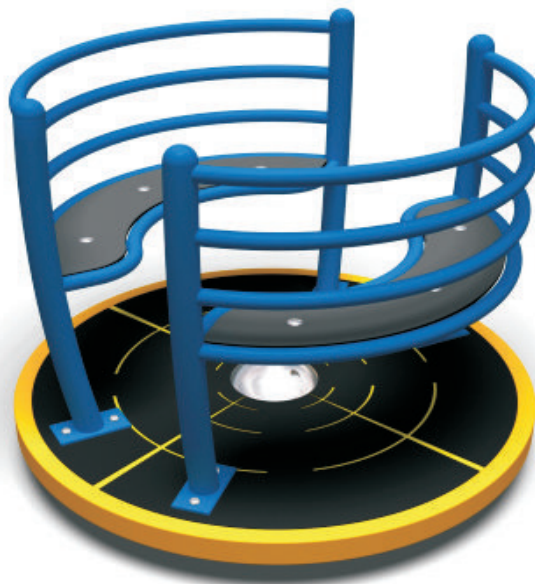

INSTALLATION INSTRUCTION

1. Excavate area for the surfacing as shown in either Fig 1 or Fig 2(not required for grass mat)
2. Excavate hole and lower ground anchor into position and level in all directions. See Fig 3
3. Pour in 0.25m³ of low slump concrete and vibrate down with vibrating poker.
4. Re-check levels ensuring spindle is vertical and level

Do not leave unattended until satisfied the concrete has cured or the site is secure.

5. Assemble bearings, speed restrictor and roundabout ring as per Fig. 4. Ensure ring spins freely.
6. Attach roundabout top as per Fig. 5, ensuring pre drilled holes in the polydek floor align with the inserts located in the base ring framework.

On completion of the installation, a post-installation inspection should be carried out by a competent person to assess compliance with the relevant part(s) of BS EN 1176:2008.

Surfacing Dimensions

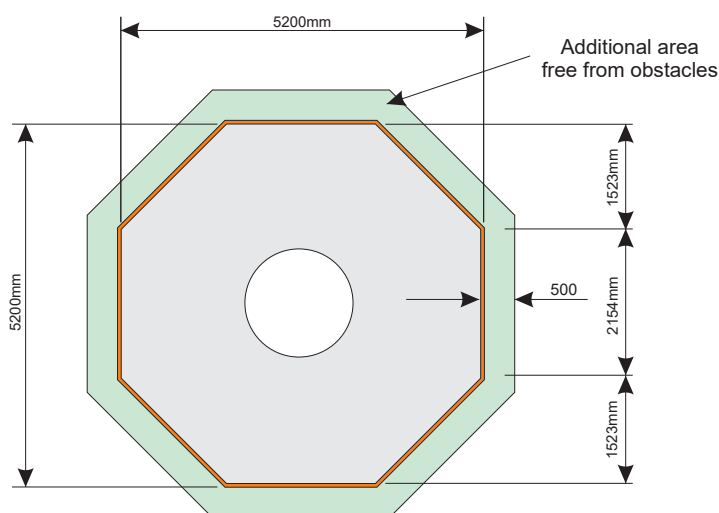

Hexagonal Base (fig 1)

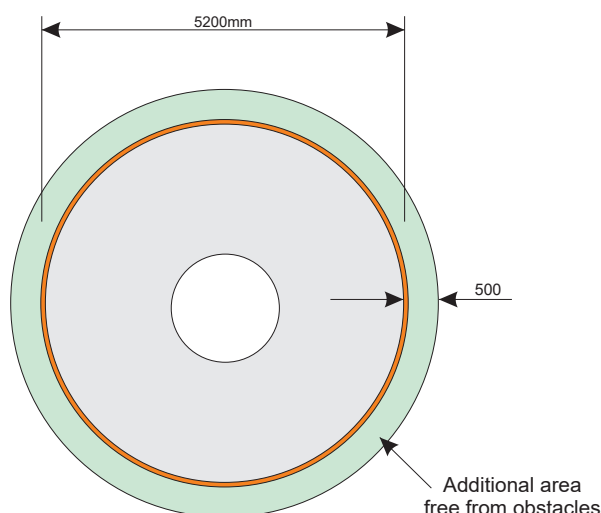

Circular Base (fig 2)

Wetpour/Tile Surfacing(fig 3)

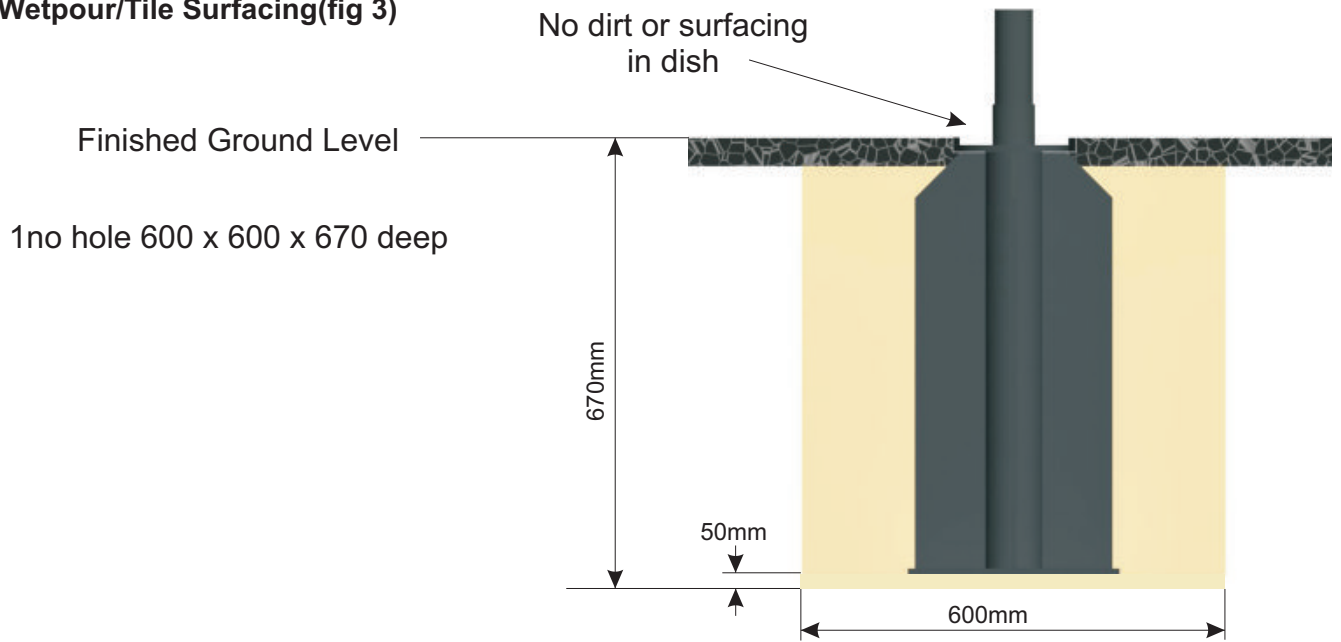

Bearing Assembly(fig 4)

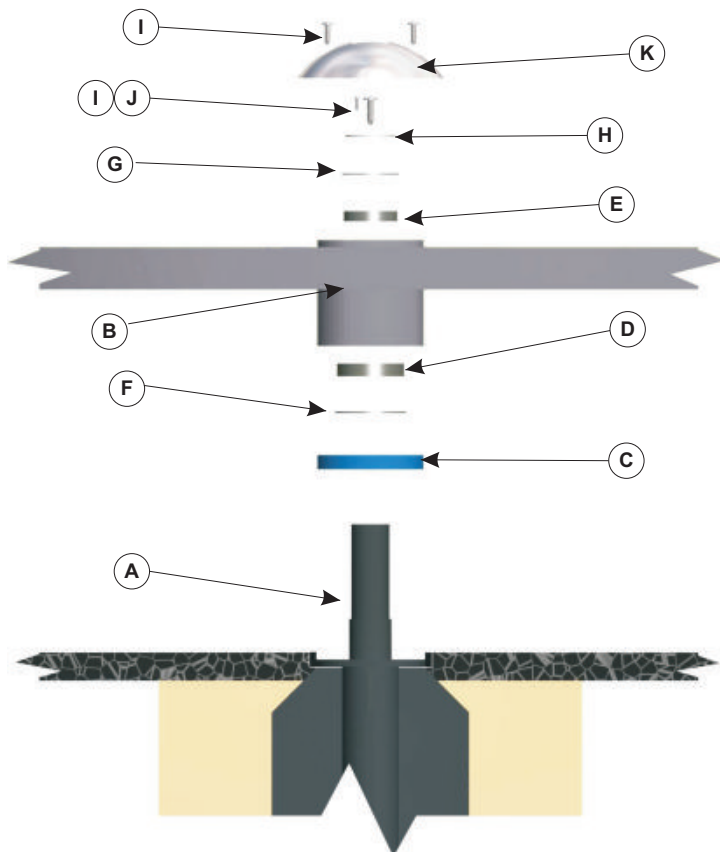

Roundabout Top Attachment(fig 5)

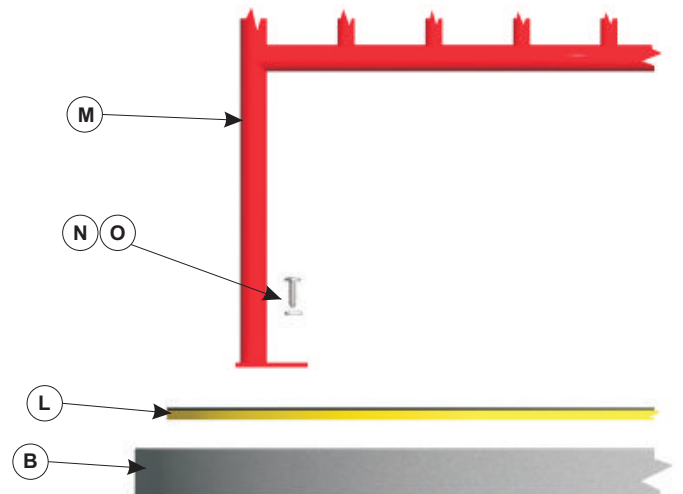

Component List

Ref	Main Parts	Qty
A	Ground Anchor & Shaft	1
B	Base Ring & Bearing Housing	1
C	Nylon Speed Restrictor	1
D	Larger Bottom Bearing	1
E	Smaller Top Bearing	1
F	Larger Retaining Circlip	1
G	Smaller Retaining Circlip	1
H	Retaining Washer	1
I	M10 x 40mm Resistorx Bolt	3
J	M10 x 40mm Hexagonal Bolt	1
K	Cover Cap	1
L	HDPE Polydek Floor	1
M	Roundabout Top	2
N	10mm Steel Washer	8
O	M10 x 50mm Resistorx Bolt	8

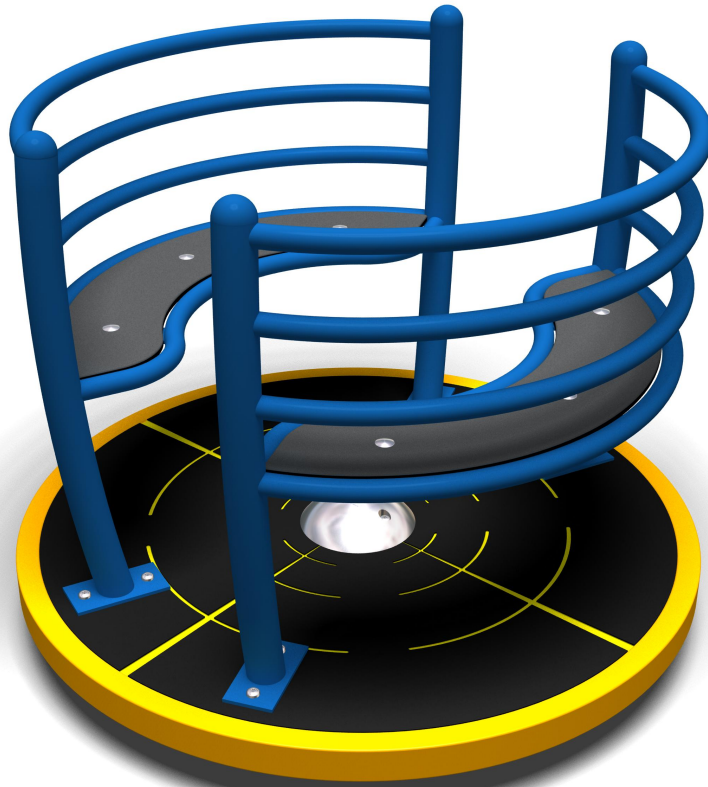

✓ All Play & Leisure's product range is fully compliant with **BS EN 1176:2008**

Technical AT-A-GLANCE

Product Code	ERB01
Equipment Size	1200L x 1200W x 945H
Minimum Space	5200 x 5200
Free Height of Fall	545
Safety Surface Area	23m ²

Side Elevation

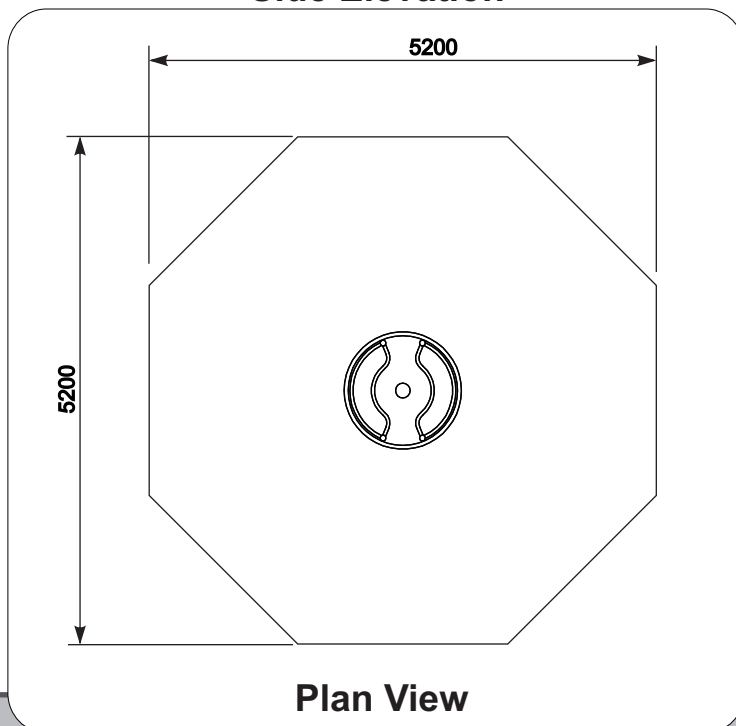

Twister - ERB01

Maintenance & Inspection

The Twister should be inspected and maintained in accordance with the recommendations as detailed in BS EN 1176-7:2008

If any part of the equipment is found to be unsafe during an inspection and cannot be immediately rectified the equipment should be protected against further use.

Routine Visual Inspection.

Routine visual inspections are to be conducted to identify obvious hazards resulting from vandalism, use or weather conditions. e.g. Hazards such as broken parts or broken bottles.

Operational Inspection.

To reduce accidents the operator should ensure an appropriate routine maintenance schedule is established, implemented and maintained. Inspection shall be carried out on a monthly basis, although consideration should be taken regarding local conditions and usage.

During a operational inspection the following should be included:

- Tightening of fastenings.
- Re-painting and re-treatment of surfaces.
- Maintenance of any impact attenuating surfaces.
- Marking of equipment to signify loose fill finished surface levels.
- Cleaning.
- Removal of broken glass and other debris or contaminants.
- Restoring loose fills to the correct level.
- Maintenance of free space areas.

Annual Main Inspection (NOT EXCEEDING 12 MONTHS)

Inspection intended to establish the overall level of safety of equipment, foundation and playing surfaces.

- Effects of weather.
- Rotting or corrosion.
- A change in the level of safety of the equipment as a result of repairs made, or of added or replaced components

Corrective Maintenance.

Corrective maintenance should include measures to correct defects, or to-establish the necessary levels of safety of the playground equipment and surfaces. Such measures should include:

- Replacement of fastenings.
- Welding or welding repairs.
- Replacement of worn or defective parts.
- Replacement of defective structural components.

Equipment Alterations.

Alterations to parts of the Storm that could affect the essential safety of the equipment should only be carried out after consultation with Play and Leisure.

Equipment Identification

Information regarding the manufacturer, I.D. Number, year of manufacturer and the European Standard is displayed on a plaque at the centre of the housing cap(see fig 4)

Issue. No.	<input type="text" value="1"/>	Created By:	<input type="text" value="B. Moss"/>	Date:	<input type="text" value="06/08/14"/>	Signed:	<input type="text" value="B MOSS"/>
Issue. No.	<input type="text"/>	Created By:	<input type="text"/>	Date:	<input type="text"/>	Signed:	<input type="text"/>
Issue. No.	<input type="text"/>	Created By:	<input type="text"/>	Date:	<input type="text"/>	Signed:	<input type="text"/>