

3m Cone Climber

CC30

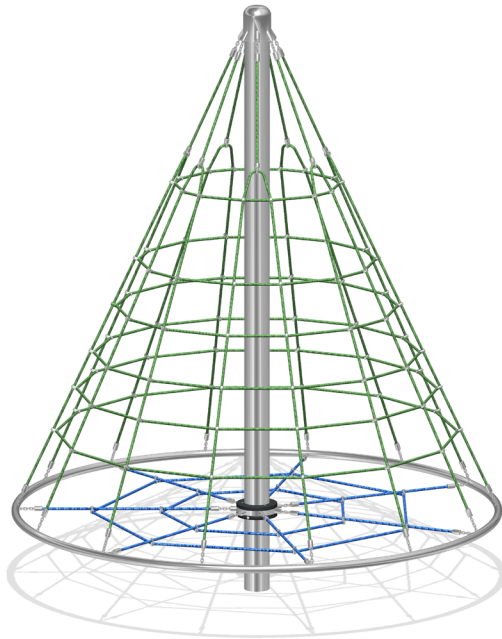

3+



5



6hrs



2050



32.16



6.4m x 6.4m

The 3m Cone Climber is a striking climbing structure that offers a high-level challenge for confident and adventurous children. The expansive rope net develops strength, balance, coordination, and spatial awareness, while encouraging problem-solving and risk assessment as children explore different climbing routes. Its impressive height and open design make it a focal point for active play, promoting confidence, resilience, and social interaction as children climb, rest, and play together.

Key



Age Range



Number Of Users



Assembly Time



Free Fall Height



Impact Area



Wheelchair Accessible



Space Needed



For All Users

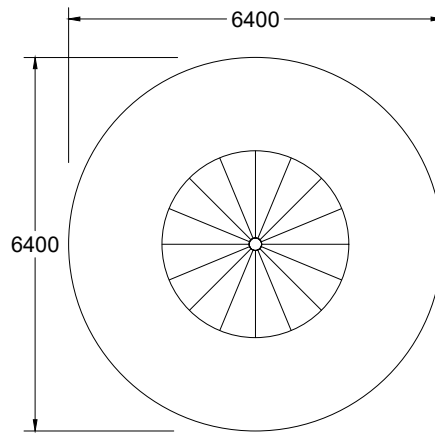

Specification	
Age Range:	3+ Years
Safety Area Width (mm):	6400
Safety Area Length (mm):	6400
Safety Area (m ²):	32.16
Free Fall Height (mm):	2050
Assembly Time:	6 hrs
People For Installation:	2

There shall be an additional area with a length of 500mm in the rotating direction (All Around) free from obstacles.



Inclusive Information

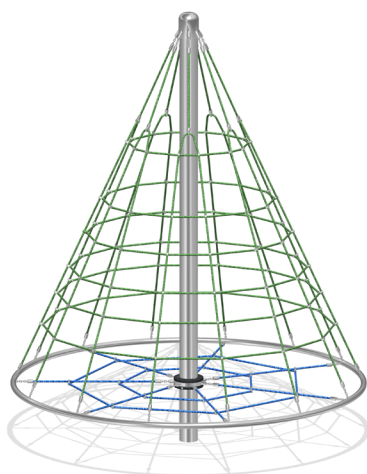

COMMUNICATING



COMPETING



WORKING TOGETHER



SHARING



SPINNING AND ROLLING



CLIMBING

Guaranteed for product lifetime against structural failure



Guaranteed for 5 years

Guaranteed for 5 years



Guaranteed for 8 years

Guaranteed for 10 years



Guaranteed for 2 years

Guaranteed for 2 years



Guaranteed for 1 year

Play Panels + HDPE Products



For consumable parts:
- Beaters
- Cables



For electronic failure caused by manufacturing defects in:
- Speakers
- Sound chips
- Circuit boards



For mechanical failure caused by faulty workmanship or material defects in:
- Moving parts
- Standing and heavy duty springs



For defects resulting from the manufacture of:
- High density polyethylene sheets
- Structural steel components