

Material & Product Details

Steel sections are all mild steel to the relevant BS EN steel standards

Chains are 8mm short link sherardised mild steel

Fixings are mostly BZP, high tensile steel, hex head bolts with washers and Nyloc nuts

Coatings

All steel equipment made by Play & Leisure is shotblasted to SA 2.5 before a 60-micron thick epoxy-based zinc phosphate primer is applied and finally a 70 micron thick coating of polyester powder.



All Play & Leisure Ltd's equipment & surfacing complies to BS EN 1176 parts 1-10, BS EN 1177 and BS EN 15312. Equipment is guaranteed for 30 years against structural failure.

Installation Instructions

1. Excavate area for the surfacing as shown in either Fig 1(not required for Grass mat)
2. Excavate 2 holes for bases as shown in Fig 2. For hole depths see Fig 3 or Fig 4 depending on surfacing required
3. Lower bases into position and level in all directions ensuring they are in-line with each other.
4. Pour in 1.5m³ of low slump concrete into each hole and vibrate down with vibrating poker.
5. Re-check levels.
6. Fit temporary protection plate(if supplied) using items y and ff.
7. Leave for 3 days prior to fitting arc

Do not leave unattended until satisfied the concrete has cured or the site is secure.

Return Visit

Remove temporary protection plate, if supplied, from base, be sure to retain items y and gg for later use.

Fit main beams(b & c) into bases. See Fig 5

The main beams requires lifting equipment capable of lifting 160kg. ie Hiab Crane or similar.

Bolt main beams(b & c) to base section using bolts as detailed in Fig 6.

Attach the support legs(d) and concrete into position. See Fig 7.

Surfacing Plan (fig. 1)

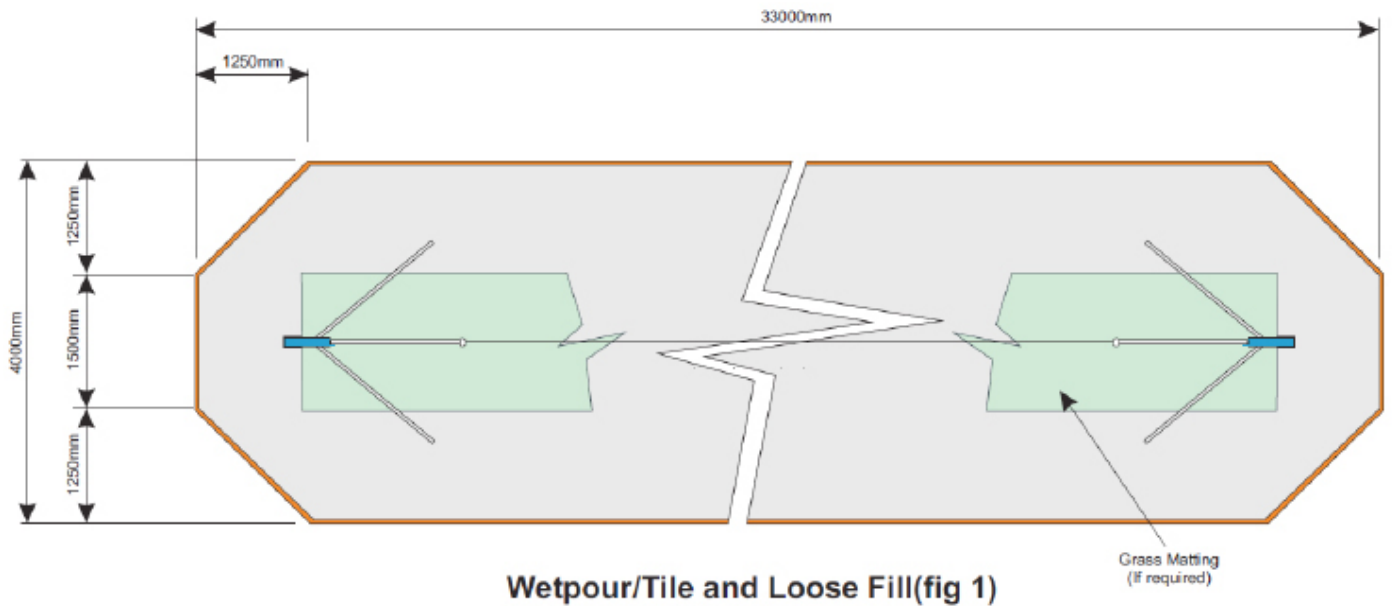

Base Foundation Details

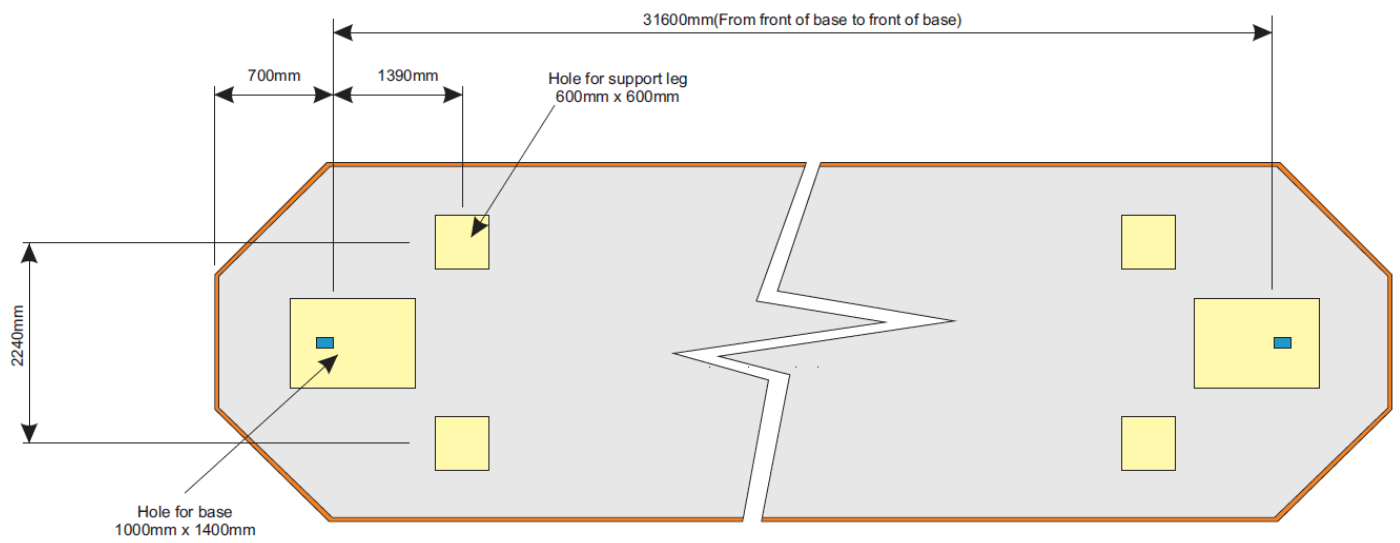

Hole Positions (fig 2)

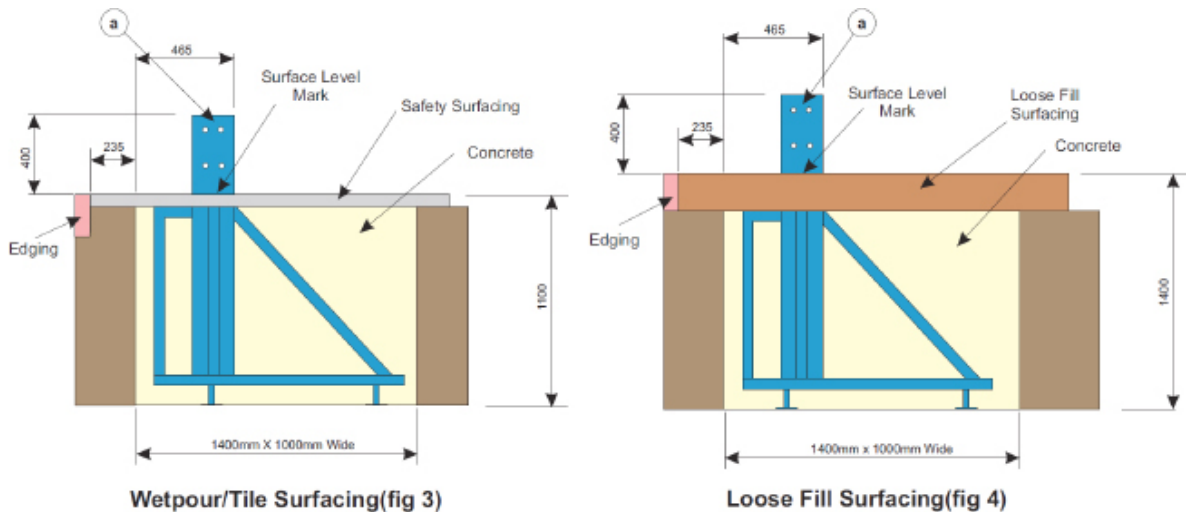

Arc Installation Details

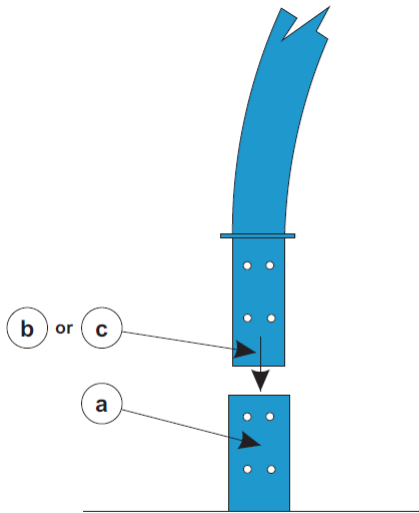

Arc Installation(fig 5)

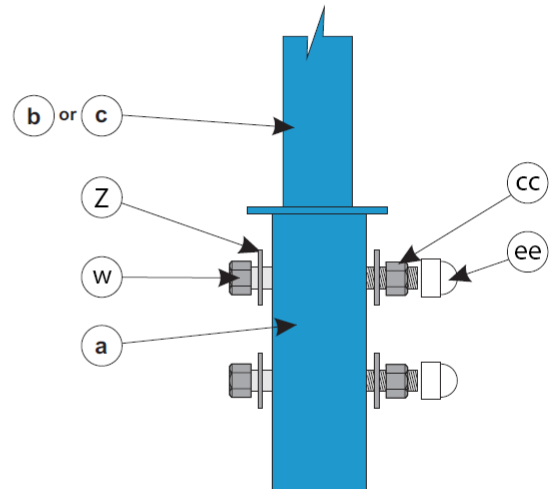

Arc Fixing(fig 6)

Support Leg Details

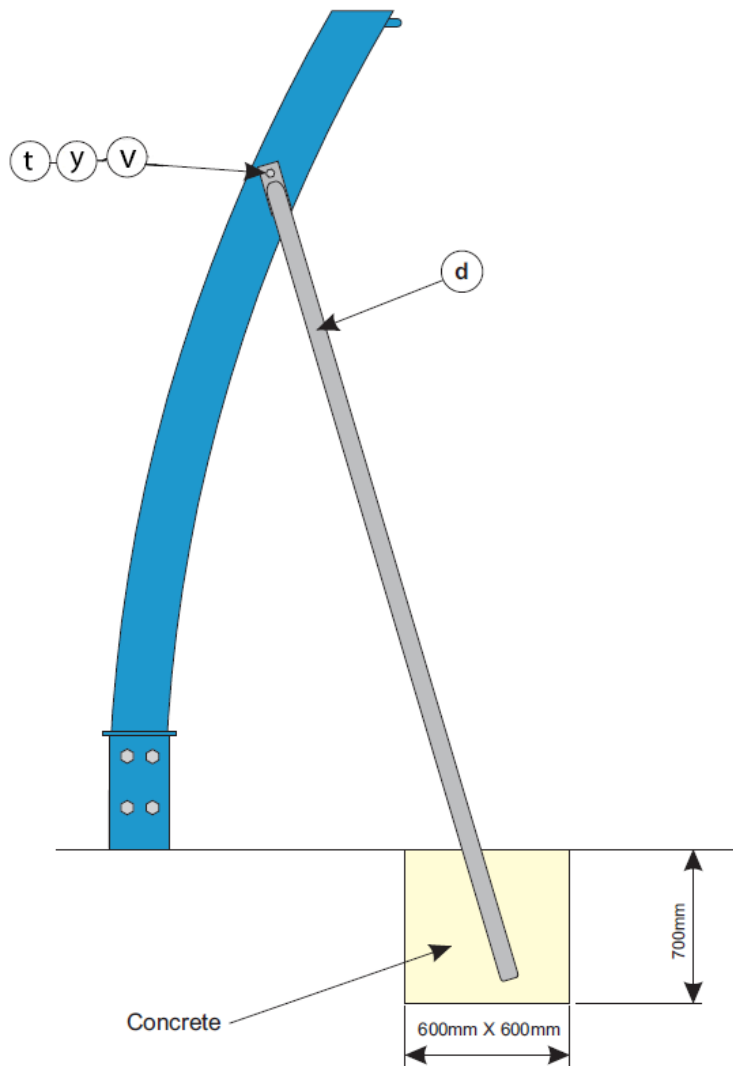

Support Leg Installation(fig 7)

Centre of hole to be positioned 700mm from the front of the main Aerial Runway beam.
 Please ensure the SHORT Aerial Runway Stop End Tube is fitted to the main beam nearest to the ramp.

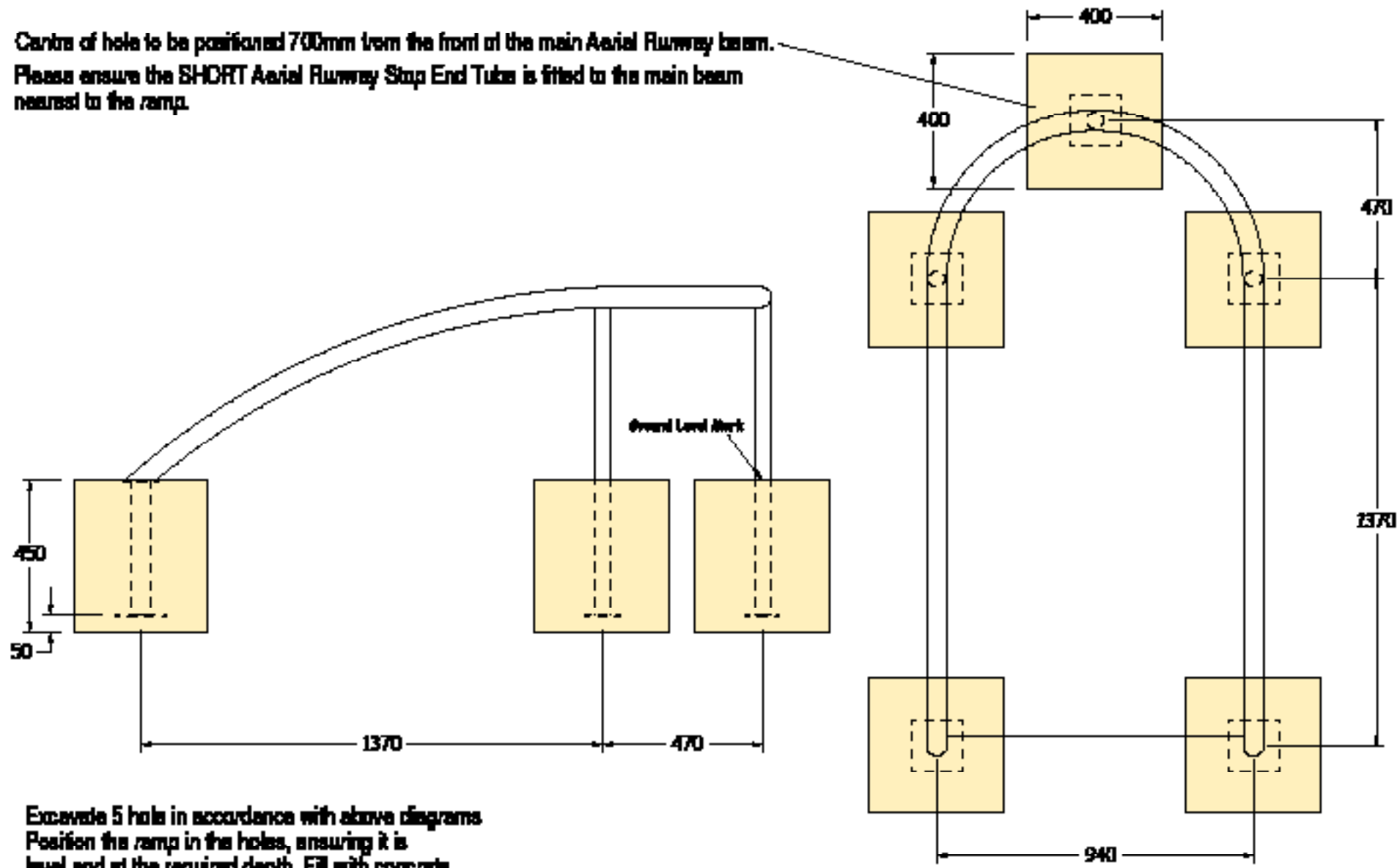

Excavate 5 hole in accordance with above diagrams
 Position the ramp in the holes, ensuring it is level and at the required depth. Fill with concrete.
 Do not allow the equipment to be used until the concrete has set (2 - 3 days)

Attach the thimble end of cable(k) to the main arc(b) using locating pin(z) See Fig 8

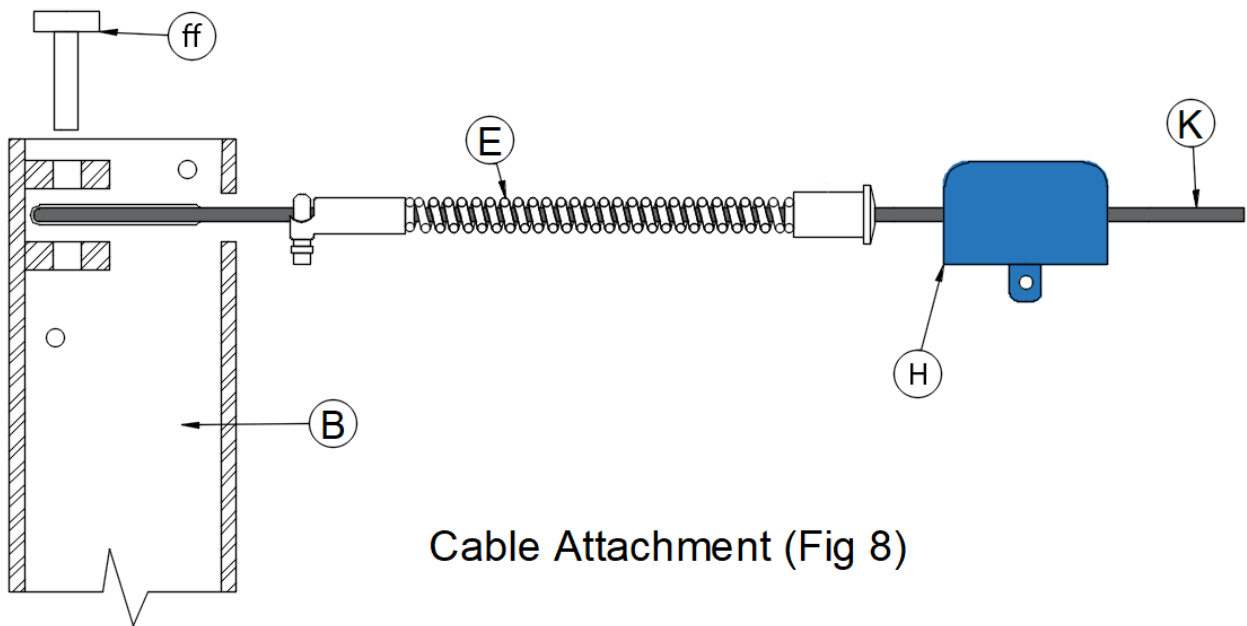

Cable Attachment (Fig 8)

Thread the cable(k) through items e-h-l-h-e, pass through arc(c) and attach to tensioner mechanism using the 2 wire clips located on the tensioner barrel. See fig 9. Place a long bar through tensioning eye and rotate anti-clockwise until desired tension is achieved.

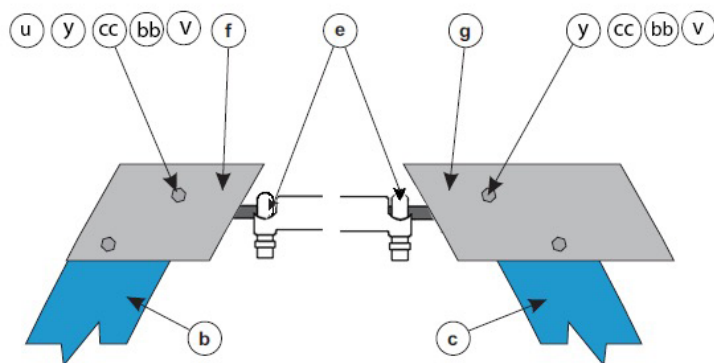
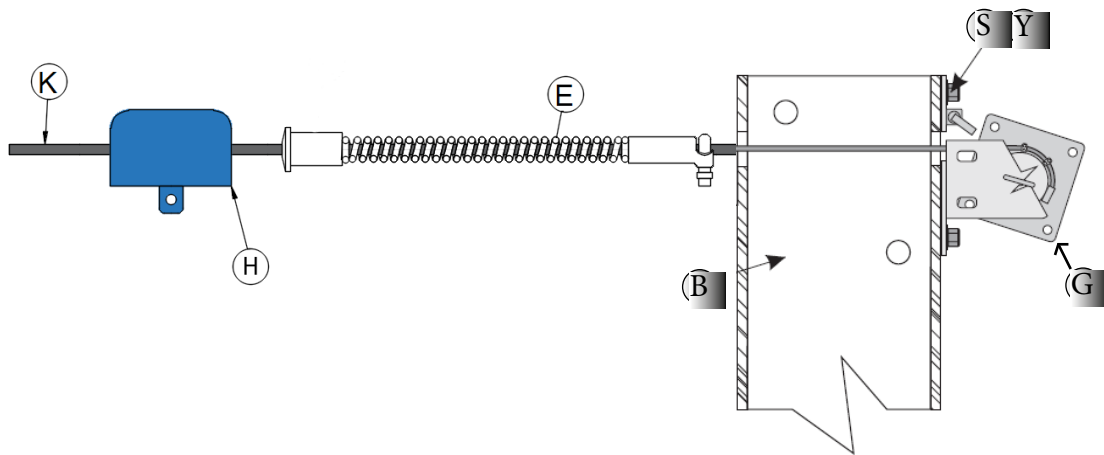

Cap Attachment (Fig 12)

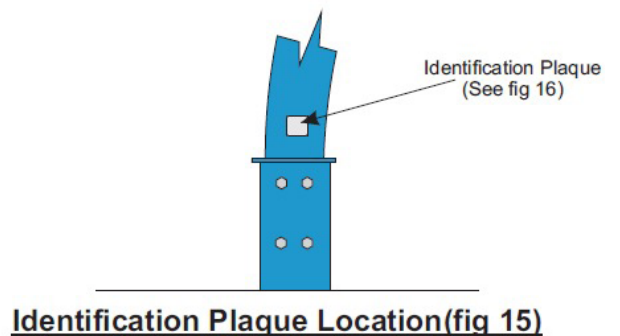

Identification Plaque Location(fig 15)

Attach Seat and chain to truck. See Fig 13

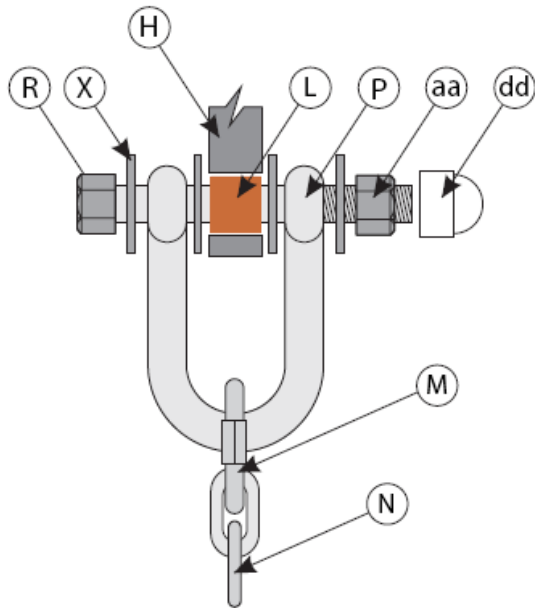

Seat Attachment - Upper (Fig 13)

Do not tighten shackles too tight making sure the shackle still moves when tightened.

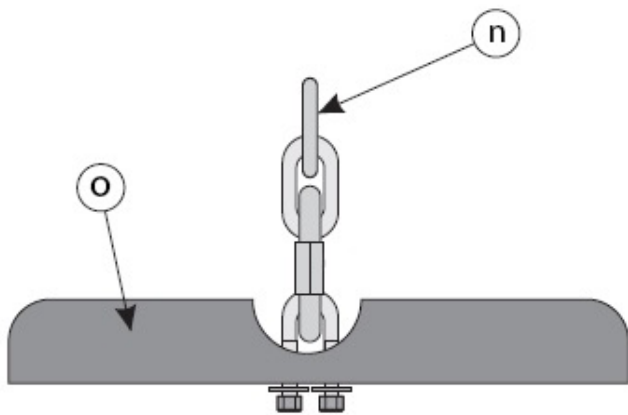

Seat Attachment - Lower (Fig 14)

Please note: a minimum seat height of 400mm from ground level is required when a weight of 130kg is applied. Seat chain(o) can be shortened to achieve the correct height if necessary.

Ref	Part Description	Part No.	Qty
A	Base		1
B	Arc		1
C	Arc With Tensioner		1
D	Support Legs		4
E	3 Meter Spring	9223	2
F	Cap - Short		1
G	Cap - Long		1
H	Truck	9064	1
K	Cable	9065	1
L	Oilite Brush		1
M	Quicklink	9017	1
N	Seat Chain	9117	1
O	Seat	9066	1
P	Shackle	9103	1
Q	Tension Mechanism		1
R	M12 x 70mm Bolt	9015	1
S	M16 x 25mm Bolt		2
T	M16 x 30mm Bolt	9060	4
U	M16 x 110mm Bolt	9061	4
V	M16 Black Caps		10
W	M20 x 130mm Bolt	9030	8
X	M12 Steel Washers	9012	4
Y	M16 Steel Washers	9041	8
Z	M20 Steel Washers	9031	16
aa	M12 Nyloc Nut	9013	1
bb	M16 Nyloc Nut	9040	4
cc	M20 Nylon Nut	9032	8
dd	M12 Black Cap	9014	1
ee	M20 Black Cap	9033	8
ff	M16 x 130mm Bolt (Locating Pin)		1

Aerial Runways - 30m w/ Ramp AR30-R

Play & Leisure



All Play & Leisure's product range is fully compliant with
BS EN 1176

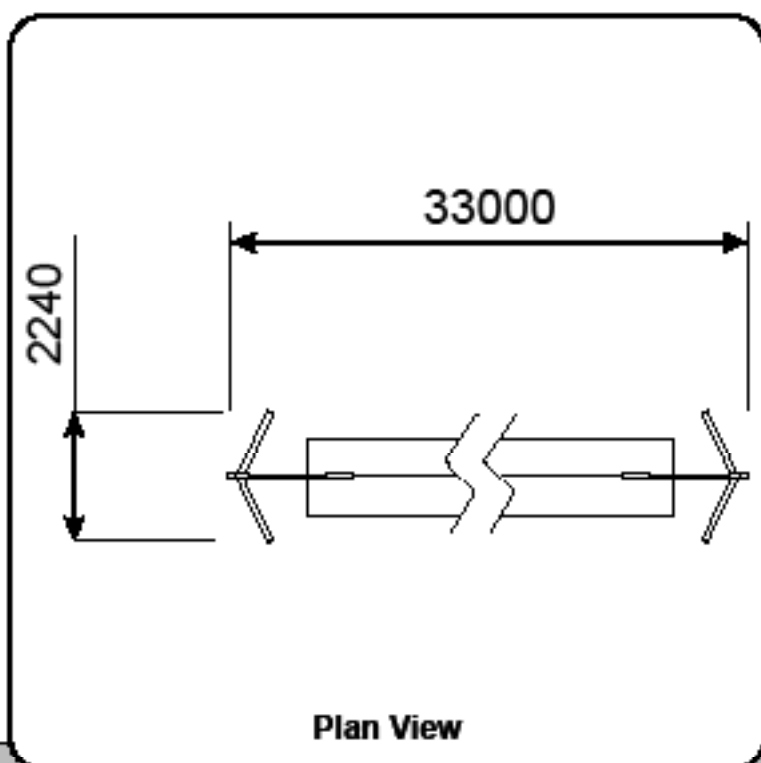

Technical Information

Product Code	AR30-R
Equipment Size (mm)	32000L x 2240W x 3600H
Minimum Space (mm)	33000 x 4000
Free Height of Fall (mm)	1000
Safety Surface Area	129m ² (Grass mat 45m ²)
User Age Range	4-14 Years

Play & Leisure Ltd

Maintenance Schedule

Maintenance & Inspection

All Play & Leisure's products should be inspected and maintained in accordance with the recommendations as detailed in BS EN 1176-7:2008

If any part of the equipment is found to be unsafe during an inspection and cannot be immediately rectified the equipment should be protected against further use.

Routine Visual Inspection.

Routine visual inspections are to be conducted to identify obvious hazards resulting from vandalism, use or weather conditions. e.g. Hazards such as broken parts or broken bottles.

Operational Inspection.

To reduce accidents the operator should ensure an appropriate routine maintenance schedule is established, implemented and maintained. Inspection shall be carried out on a monthly basis, although consideration should be taken regarding local conditions and usage.

During a operational inspection the following should be included:

- Tightening of fastenings.
- Re-painting and re-treatment of surfaces.
- Maintenance of any impact attenuating surfaces.
- Lubrication of bearings.
- Marking of equipment to signify loose fill finished surface levels.
- Cleaning.
- Removal of broken glass and other debris or contaminants.
- Restoring loose fills to the correct level.
- Maintenance of free space areas.

Annual Main Inspection (NOT EXCEEDING 12 MONTHS)

Inspection intended to establish the overall level of safety of equipment, foundation and playing surfaces.

- Effects of weather.
- Rotting or corrosion.
- A change in the level of safety of the equipment as a result of repairs made, or of added or replaced components

One Post Equipment Maintenance.

Special attention should be paid to the stability of products being of a one post design.

Corrective Maintenance.

Corrective maintenance should include measures to correct defects, or to establish the necessary levels of safety of the playground equipment and surfaces. Such measures should include:

- Replacement of fastenings.
- Welding or welding repairs.
- Replacement of worn or defective parts.
- Replacement of defective structural components.

Equipment Alterations.

Alterations to parts of any products that could affect the essential safety of the equipment should only be carried out after consultation with Play and Leisure.

Equipment Identification

Information regarding the manufacturer, I.D. Number, year of manufacturer and the European Standard is displayed on an identification plaque.